

# «ПАНЦИРЬ-С1»

РОССИЙСКИЙ САМОХОДНЫЙ  
ЗЕНИТНЫЙ РАКЕТНО-  
ПУШЕЧНЫЙ  
КОМПЛЕКС

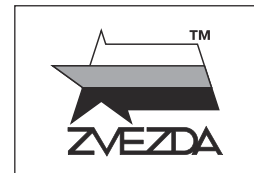

№3698

МАСШТАБ 1:35  
SCALE



## "PANTSIR-S1" RUSSIAN SELF-PROPELLED ANTI-AIRCRAFT SYSTEM

СДЕЛАНО В РОССИИ  
MADE IN RUSSIA

Зенитный ракетно-пушечный комплекс "Панцирь-С1" – система противовоздушной обороны ближнего действия. "Панцирь-С1" создан в 1994 году и принят на вооружение в 2010 году. Зенитный ракетно-пушечный комплекс "Панцирь-С1" предназначен для прикрытия гражданских и военных объектов, в том числе комплексов ПВО большой дальности, от всех современных и перспективных средств воздушного нападения. Комплекс оснащен двухдиапазонной трехкоординатной радиолокационной станцией с фазированной антенной решеткой, а также скорострельными автоматическими пушками и радиоуправляемыми ракетами.

The Pantsir-S1 is a close range cannon and missile air defense system used by the Russian Army. Design started in 1994 and it was adopted by the military in 2010. The Pantsir-S1 air defense system is designed to provide air defense for civilian and military facilities, including long-range air defense systems, protecting them against all types of existing and future airborne weapon systems. The unit is equipped with a two-range 3D radar system with a phased array antenna, auto-cannon with rapid-firing guns and radio controlled missiles.

Прежде, чем приступить к сборке модели, внимательно ознакомьтесь с инструкцией.

ВНИМАНИЕ!

Сборку и окраску модели следует проводить в хорошо проветриваемом помещении вдали от источников огня.

Сборку модели производите согласно схеме. Для удобства каждая деталь на сборочной схеме обозначена номером, соответствующим номеру на литниковой рамке.

Детали следует отделять от литников ножом или другим режущим инструментом (соблюдая осторожность при работе с острыми предметами). Места среза деталей зачистите ножом или наждачной бумагой.

Модель рекомендуется окрашивать специальными красками для пластиковых

моделей, выпускаемыми предприятием «ЗВЕЗДА».

Приступая к сборке модели, заранее ознакомьтесь со схемой окраски.

Перед окраской модель рекомендуется обезжирить, например, мыльным раствором и тщательно просушить.

Краски и клей в комплект не входят.

Для сборки модели рекомендуется использовать клей, выпускаемый предприятием «ЗВЕЗДА».

Используйте минимальное количество клея. Избегайте его попадания на окрашенные поверхности модели.

ВНИМАНИЕ!

### ATTENTION - Useful advice!

Study the instructions carefully prior to assembly. Remove parts from frame with a sharp knife or a pair of scissors and trim away excess plastic. Do not pull off parts. Assemble the parts in numerical sequence. Use plastic cement ONLY and use cement sparingly to avoid damaging the model. Paint small parts before detaching them from frame. Remove paint where parts are to be cemented.

### ACHTUNG - Ein nützlicher Rat!

Vor der Montage die Zeichnung aufmerksam studieren. Die einzelnen Montageteile mit einem Messer oder einer Schere vom Spritzling sorgfältig entfernen. Eventuelle Grate werden mit einer Klinge oder feinem Schmirgelpapier beseitigt. Keinesfalls die Montageteile mit den Händen entfernen. Bei der Montage der Tafelnumerierung folgen. Die Nummer der schon montierten Teile auf dem Spritzling ankreuzen. Bitte nur Plastikklebstoff verwenden.

### ATTENZIONE - Consigli utili!

Prima di iniziare il montaggio, studiare attentamente il disegno. Staccare con molta cura i pezzi dalle stampate, usando un tagliabalsa oppure un paio di forbici e togliere con una piccola lima o con carta vetro fine eventuali sbavature. Mai staccare i pezzi con le mani. Montarli seguendo l'ordine della numerazione delle tavole. Eliminare dalla stampata il numero del pezzo appena montato, facendogli sopra una croce.

### ATENCIÓN - Consejos útiles!

Estudiar las instrucciones cuidadosamente antes de comenzar el montaje. Separar las piezas de las bandejas con un cuchillo afilado o un par de tijeras, y retirar el exceso de plástico o rebaba. No arrancar las piezas. Montar las piezas en orden numérico. Utilizar SOLAMENTE pegamento para plástico y en poca cantidad para evitar que se dane el modelo. Pintar las piezas pequeñas antes de separarlas de la bandeja. Retirar la pintura de los lugares por donde se deban pegar las piezas.

### ATTENTION - Conseils utiles!

Avant de commencer le montage, étudier attentivement le dessin. Détacher avec beaucoup de soin les morceaux des moules en usant un massicot ou bien un pair de ciseaux et couper avec une petite lame ou avec de papier de verre fin ébarbages éventuels. Jamais détacher les morceaux avec les mains. Monter les en suivant l'ordre de la numération des tables. Eliminer de la moule le numéro de la pièce qui vient d'être montée, en le bifant avec une croix. Employer seulement de la colle pour polystyrol.

### ВАРИАНТЫ СБОРКИ

### МОДЕЛИ

### THE MODEL ASSEMBLING VERSIONS

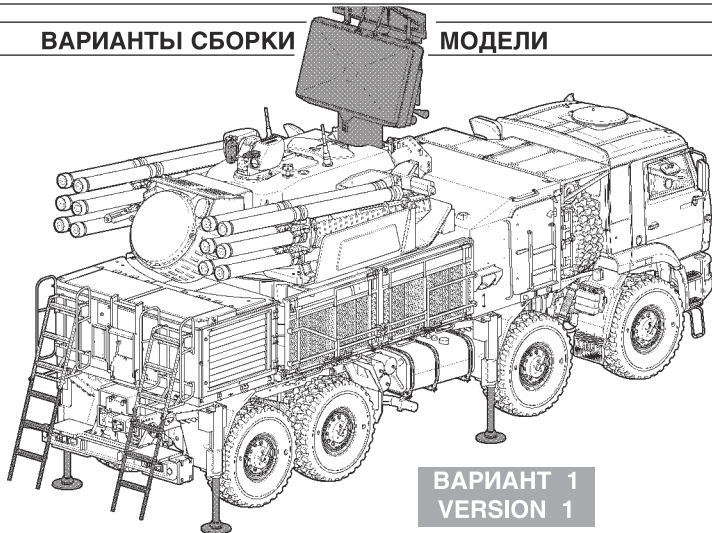

ВАРИАНТ 1  
VERSION 1

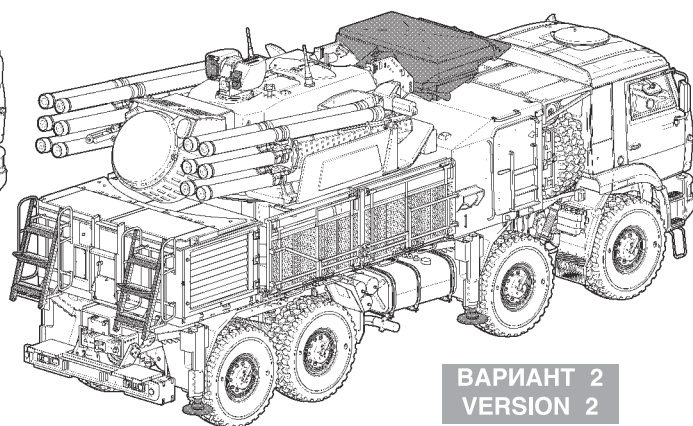

ВАРИАНТ 2  
VERSION 2

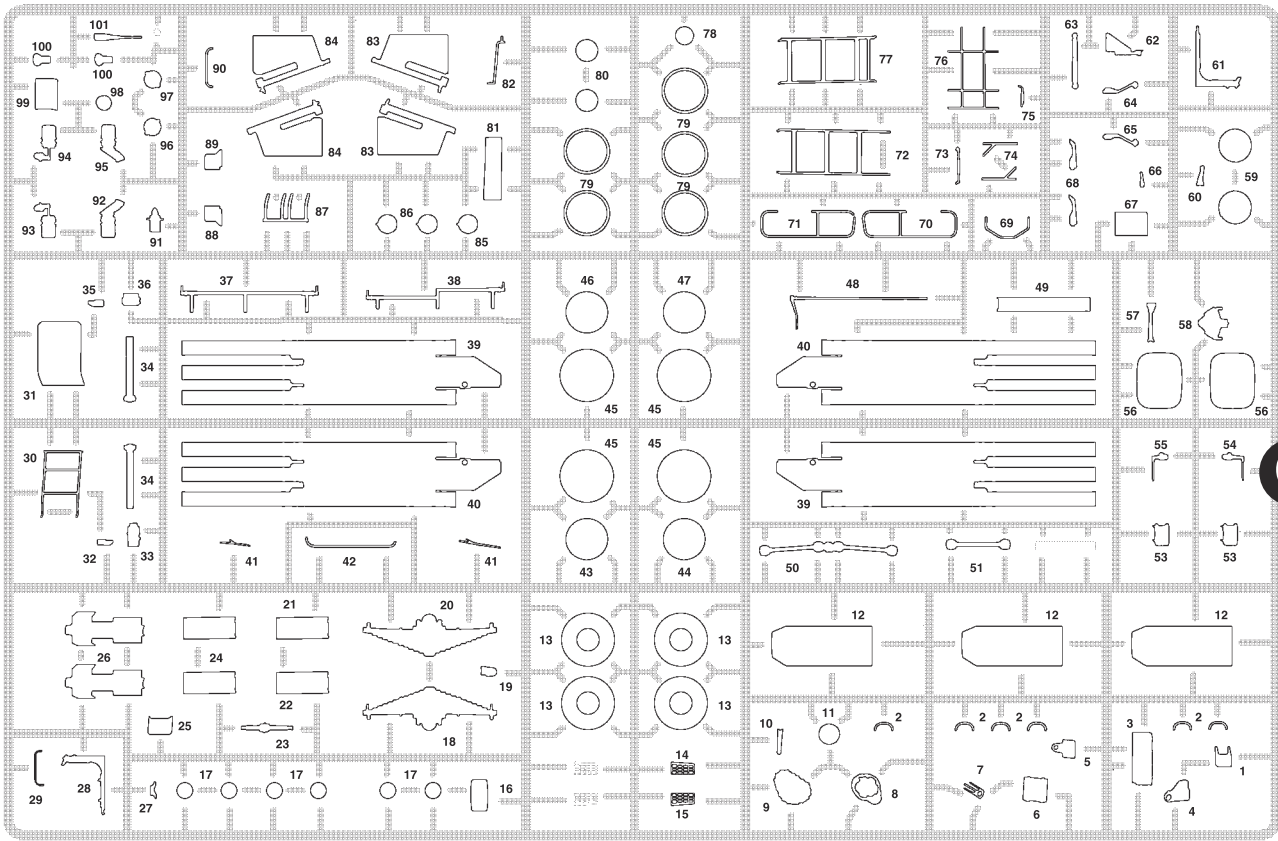

**C** x2

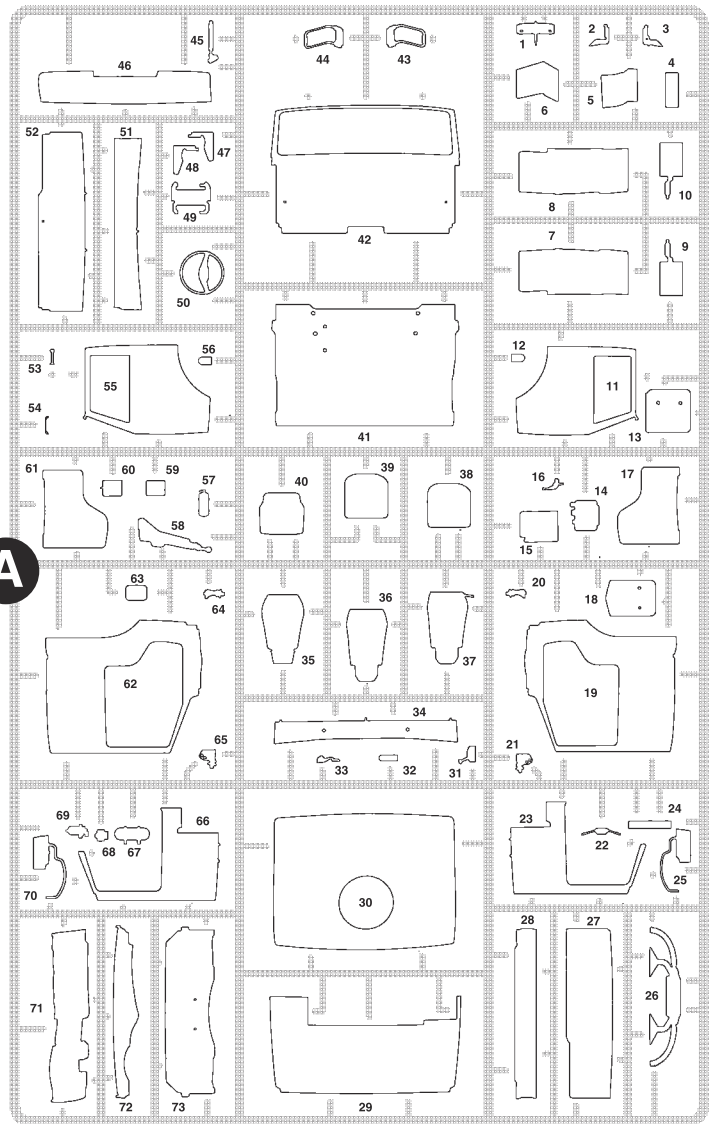
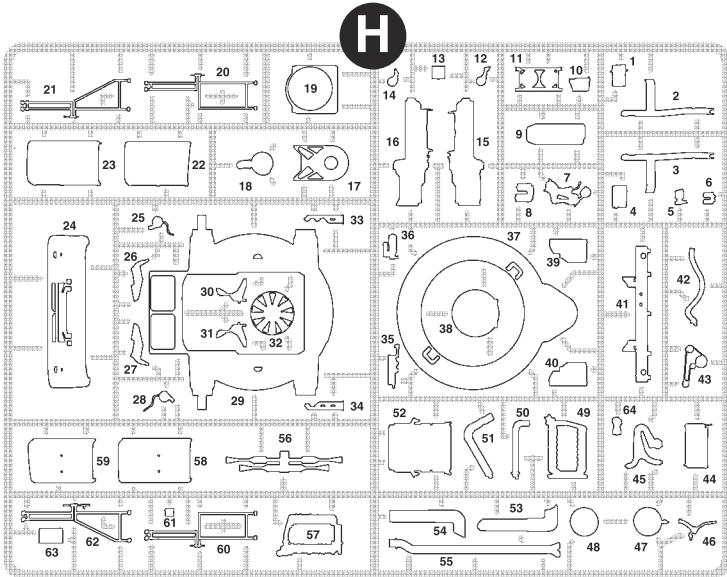
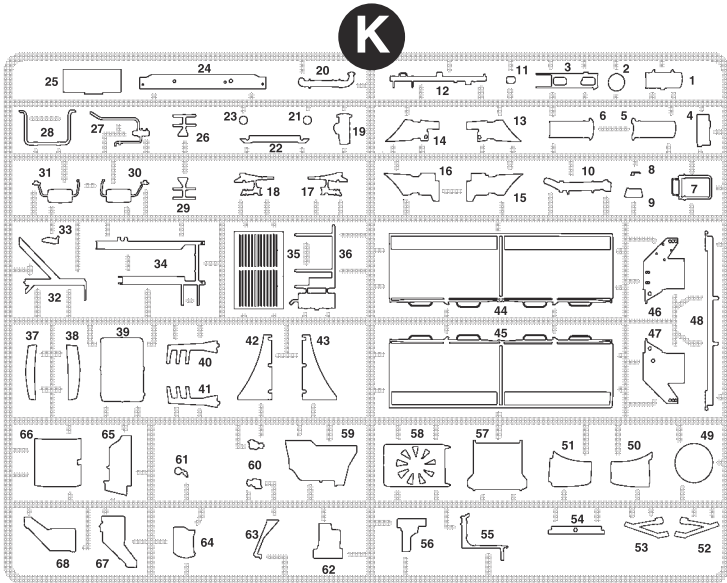

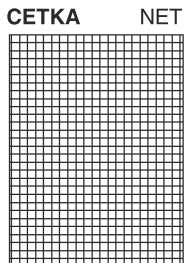
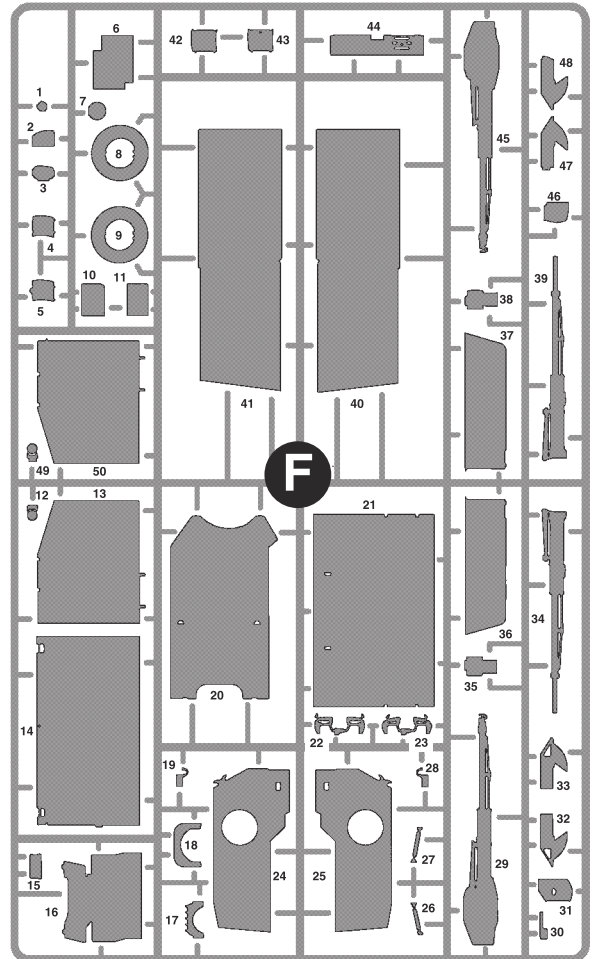
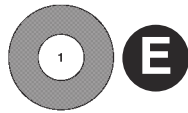
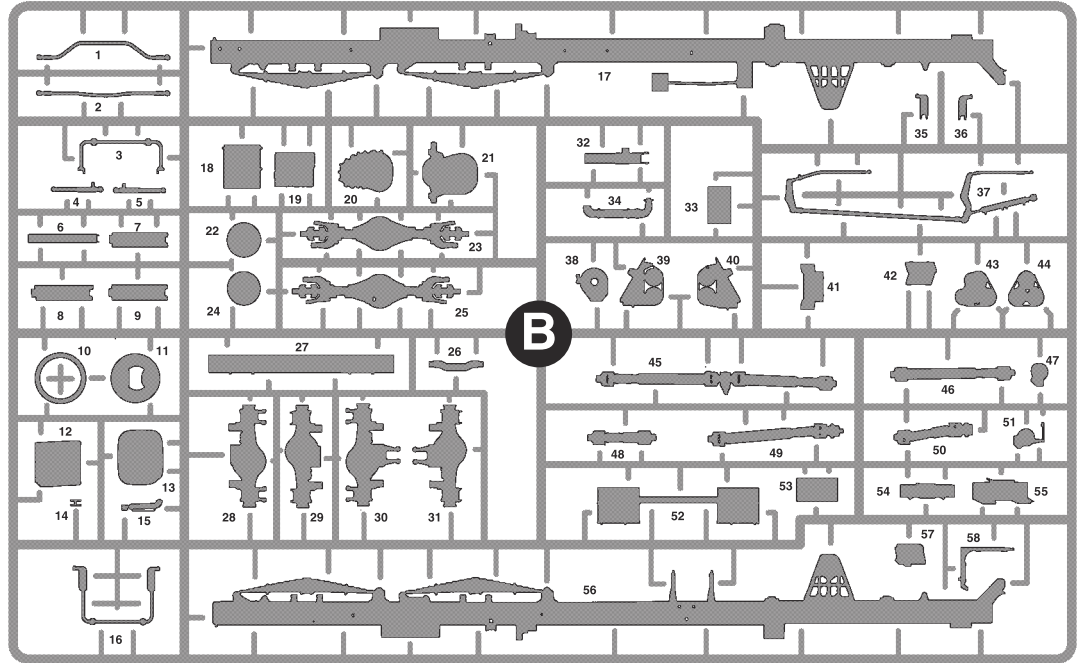
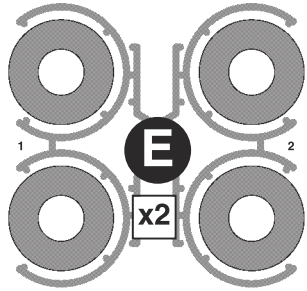
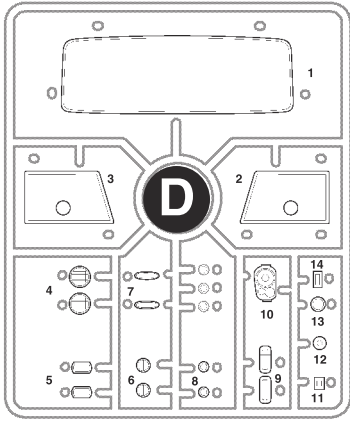

ЭТИ ИНСТРУМЕНТЫ ПОМОГУТ ВАМ КАЧЕСТВЕННО СОБРАТЬ МОДЕЛЬ:

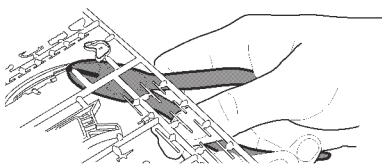

Кусачки бокорезы кат. №1101

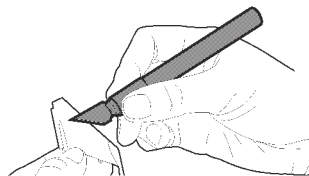

Нож цанговый кат. №1103

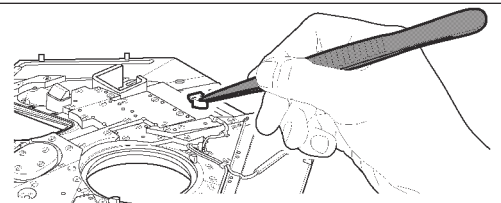

Пинцет прямой кат. №1105



Приклеить деталь на указанное место / To glue a detail on the specified place



Установить деталь на указанное место без клея / To establish a detail on the specified place without glue



Варианты сборки / Assembling versions

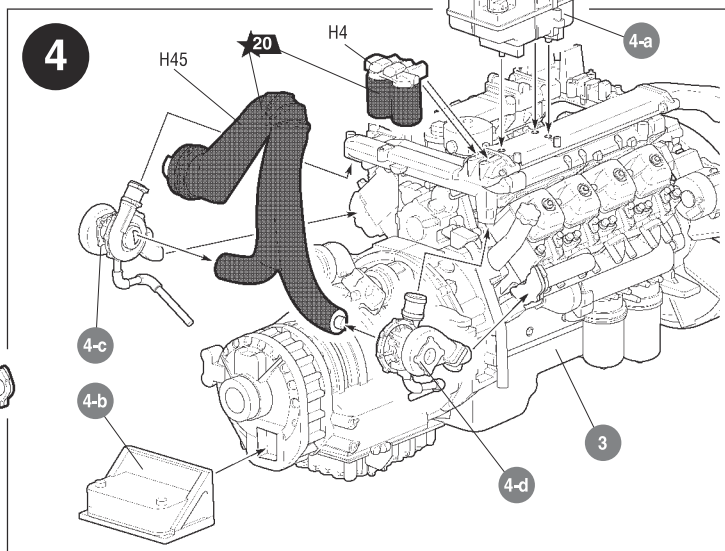
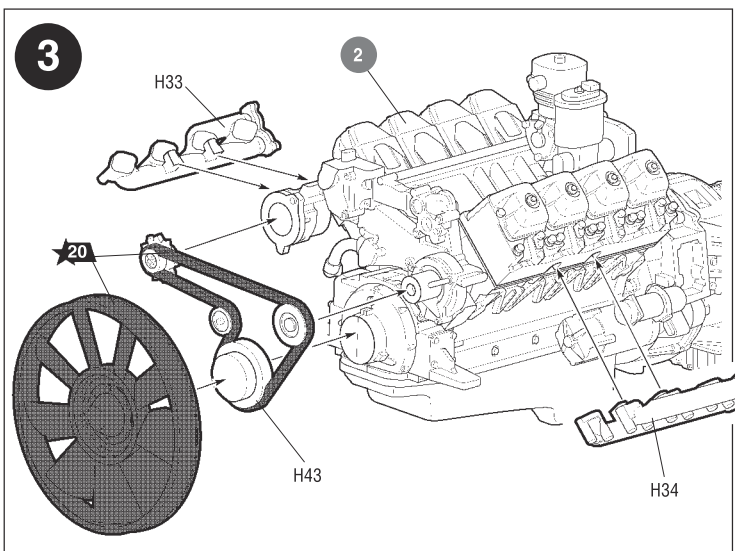
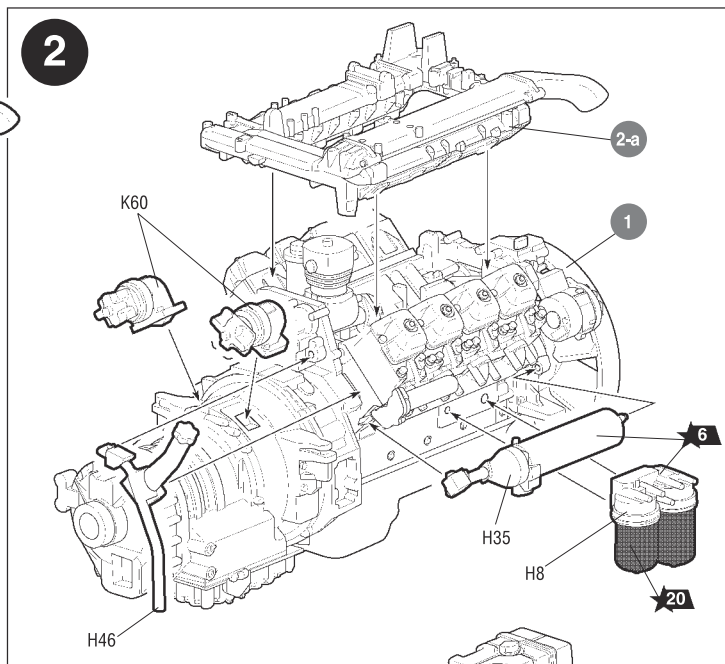
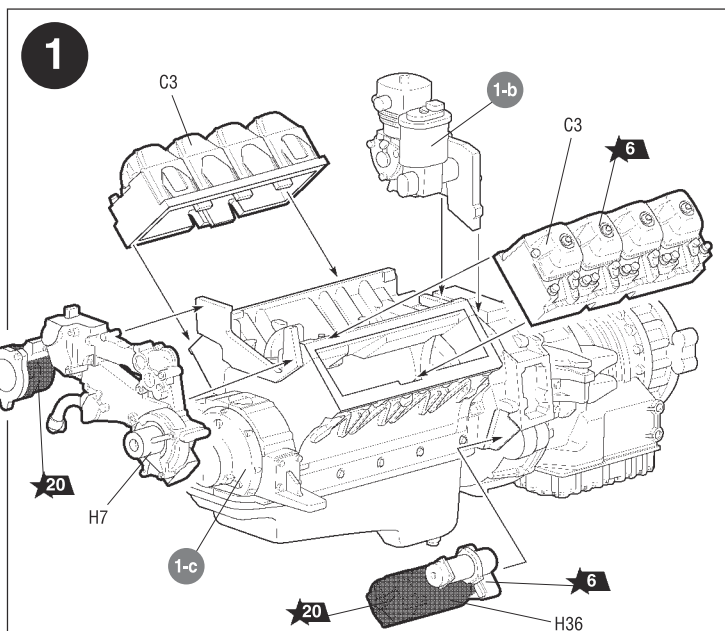
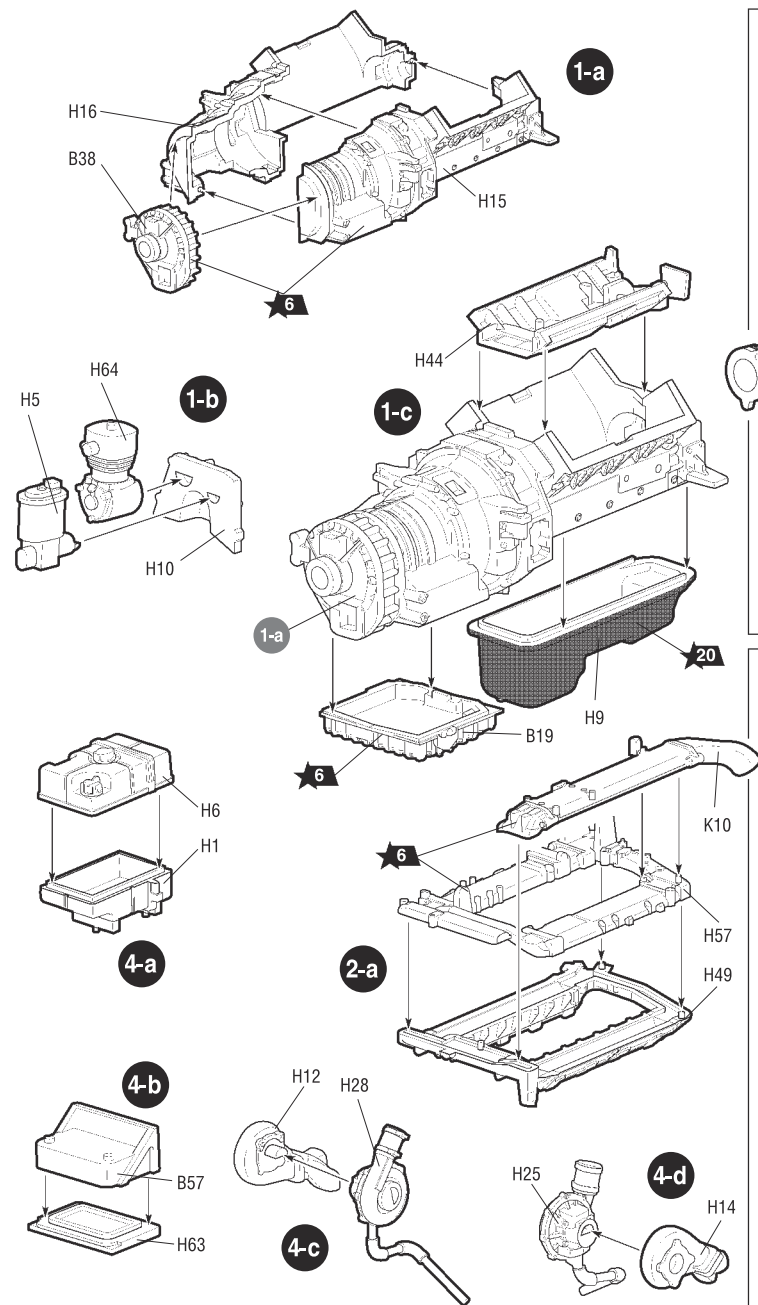

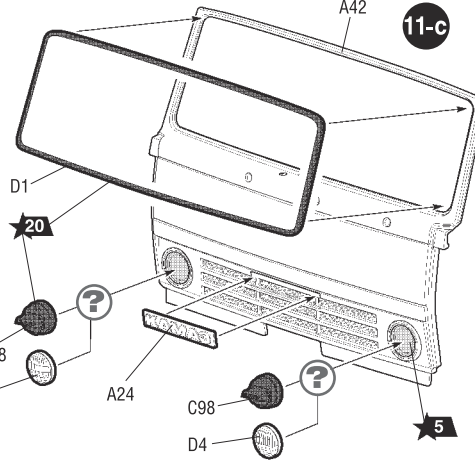
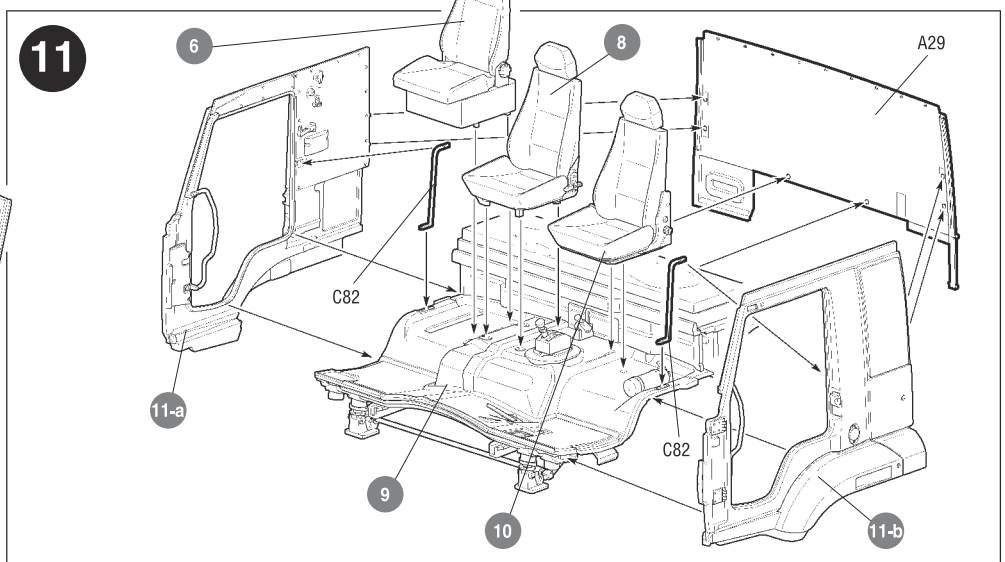
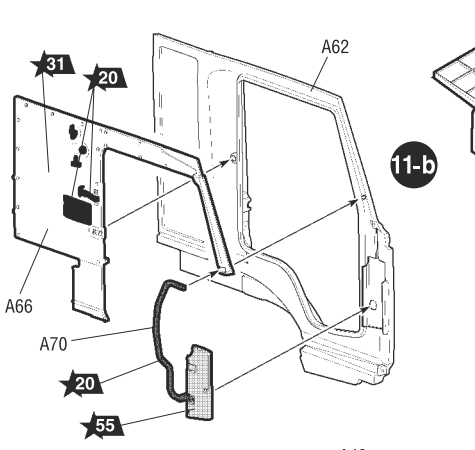
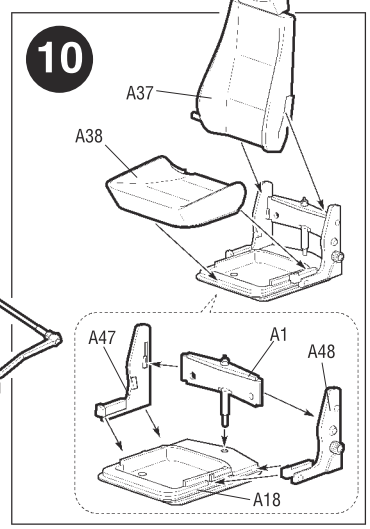
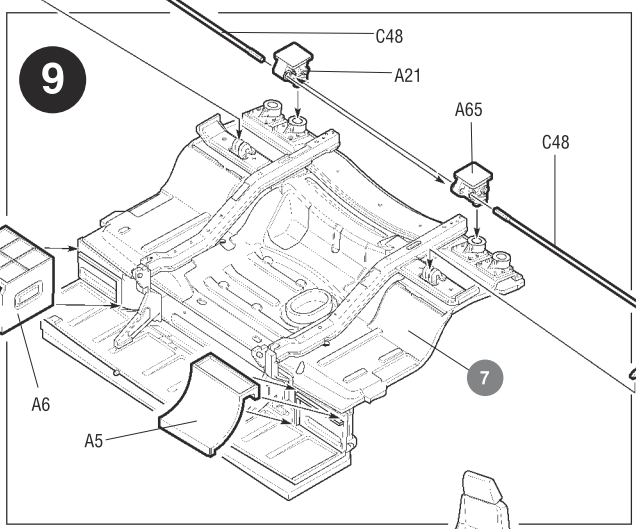
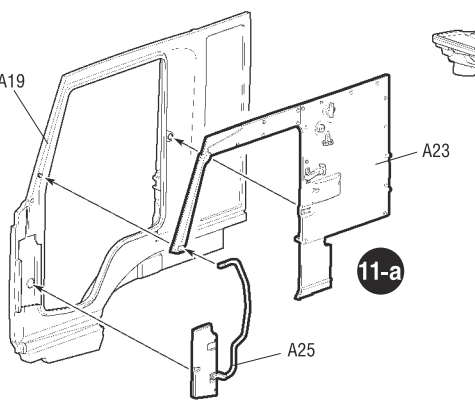
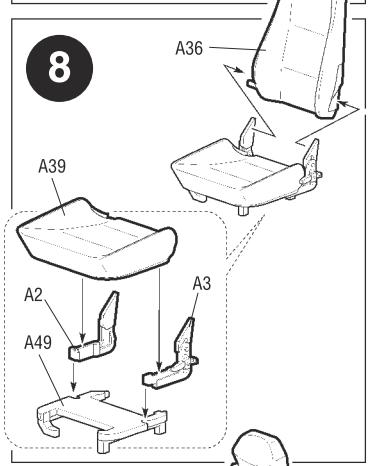
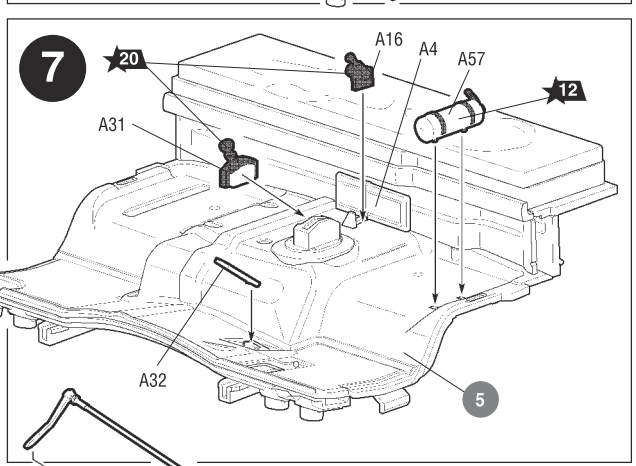
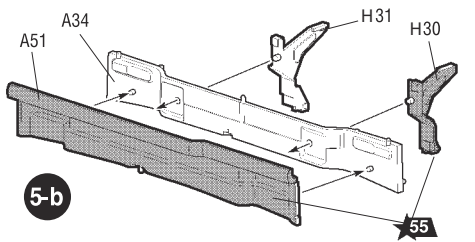
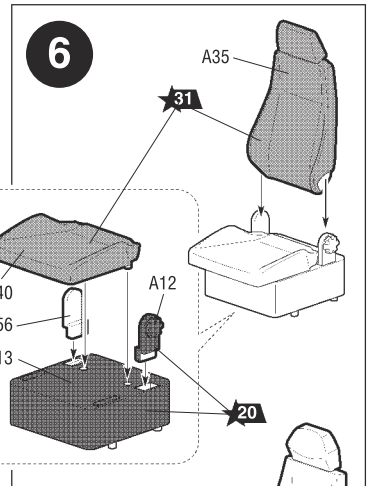
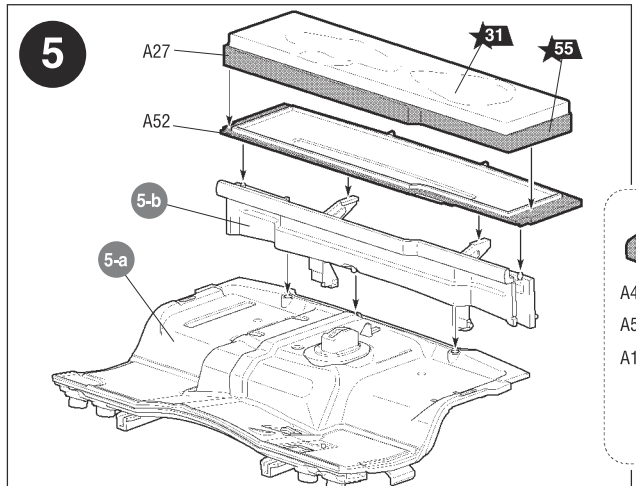
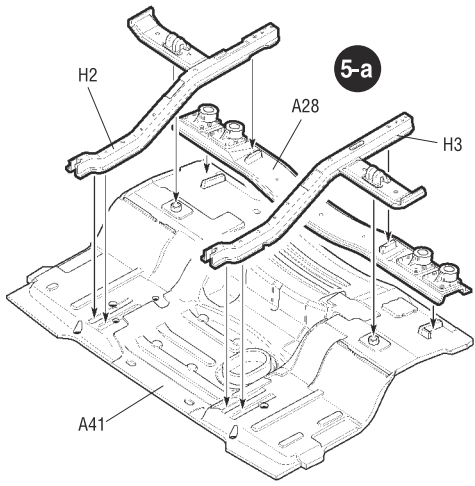

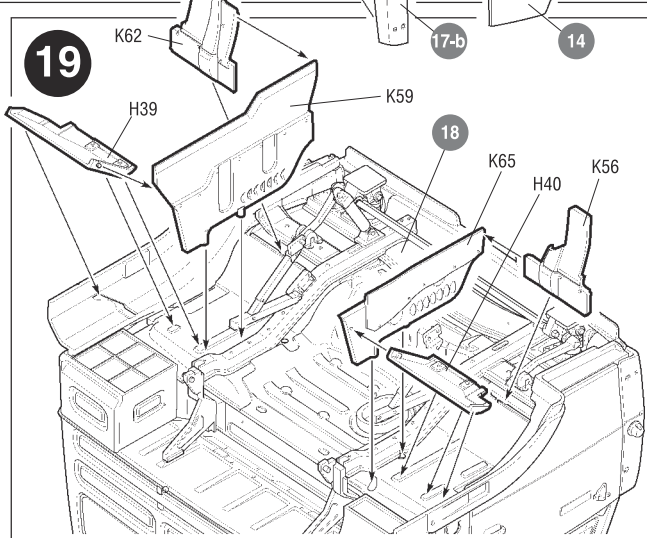
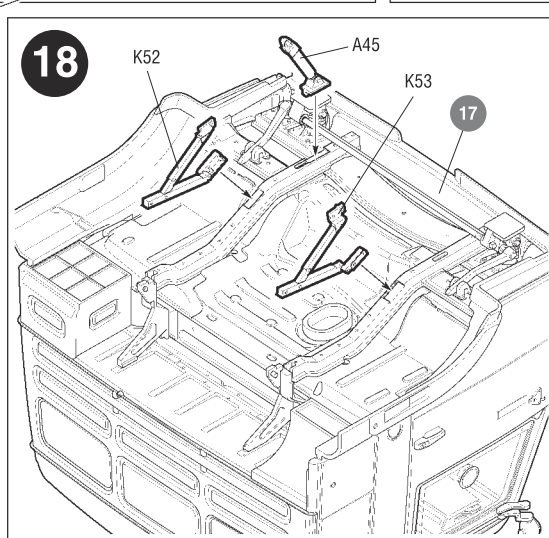
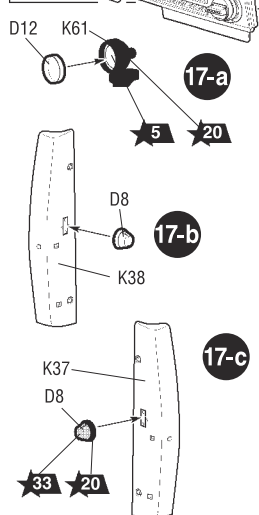
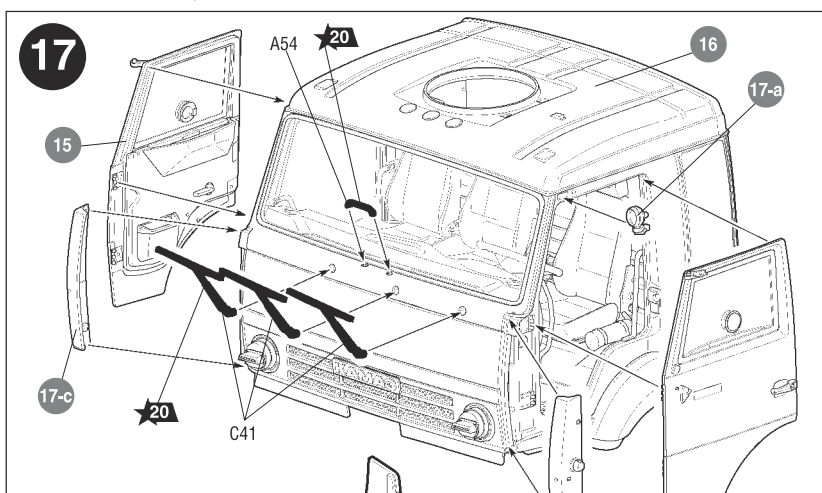
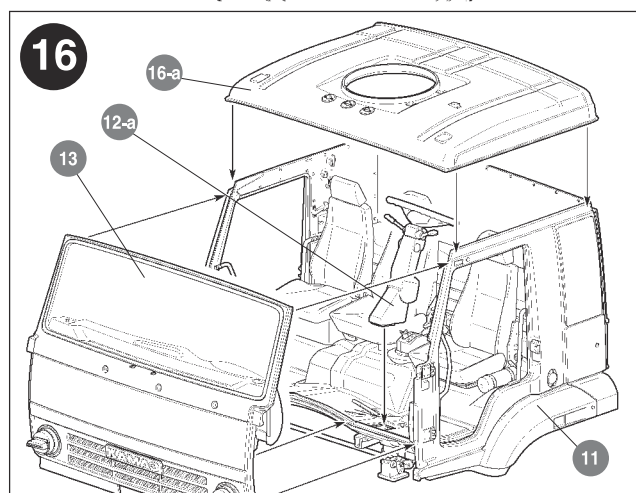
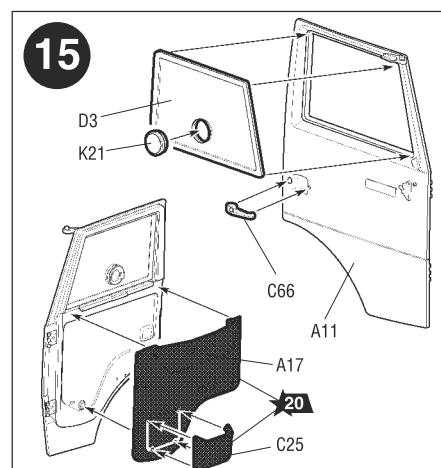
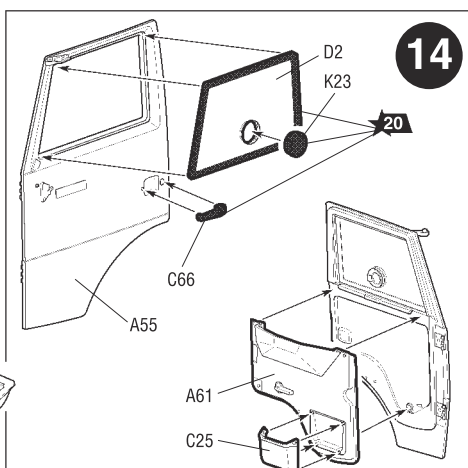
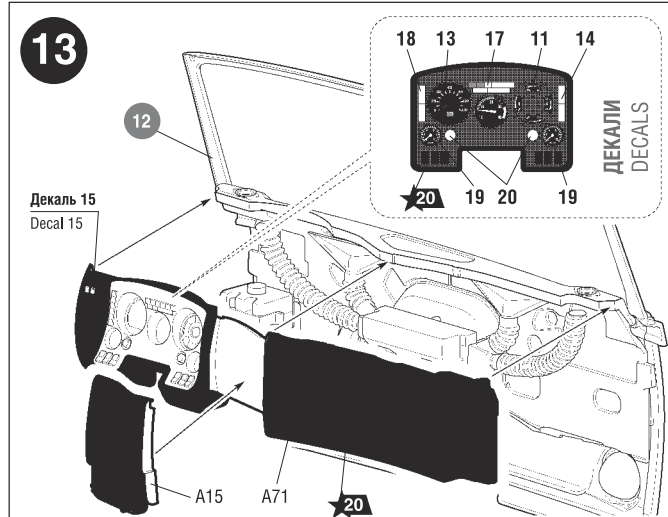
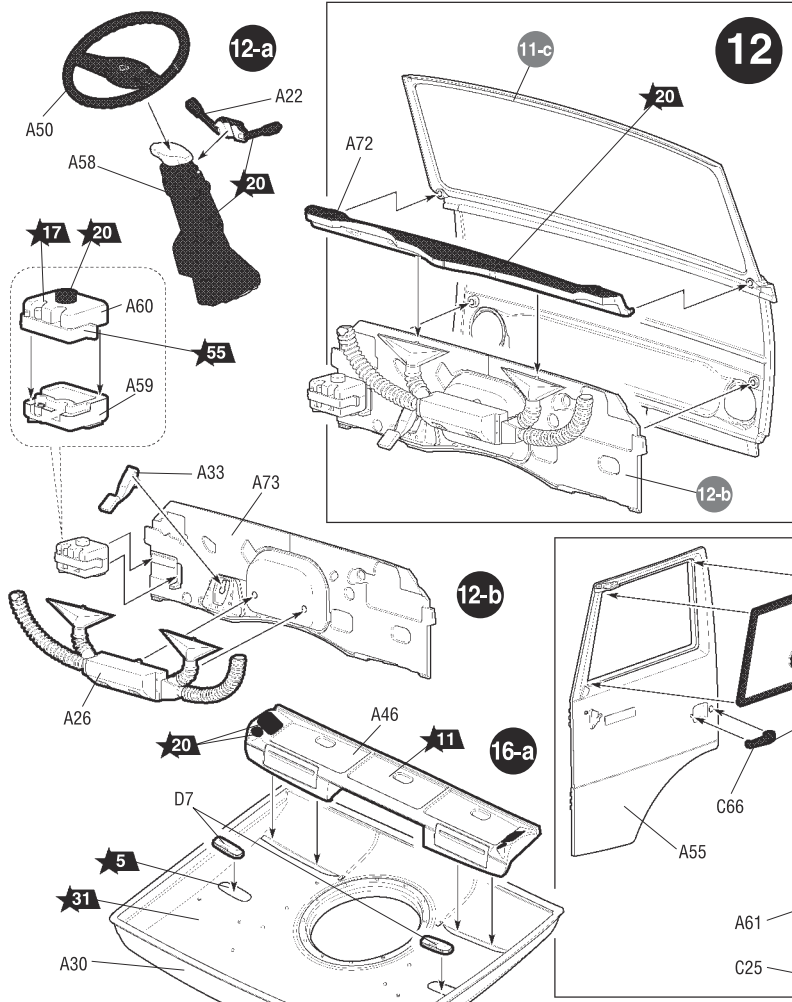

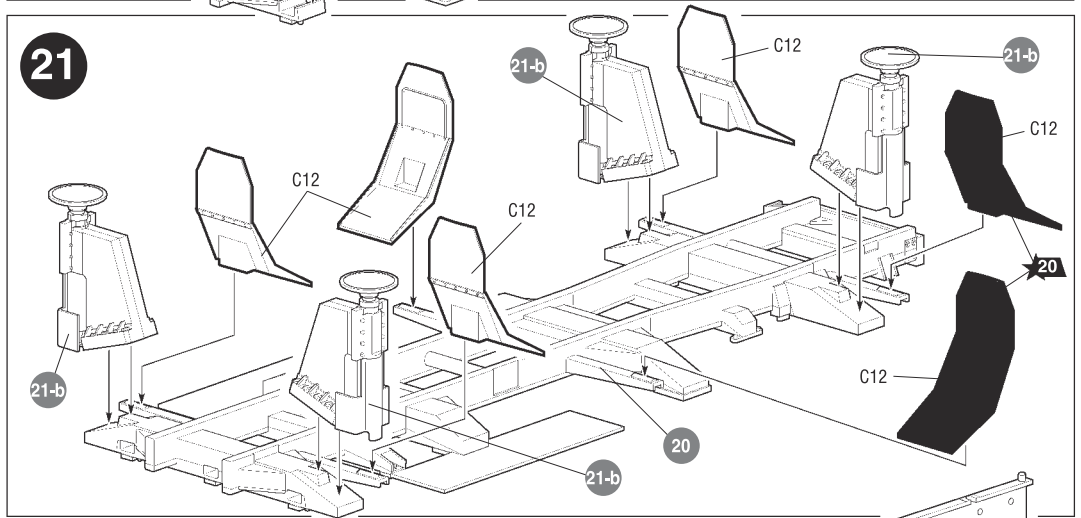
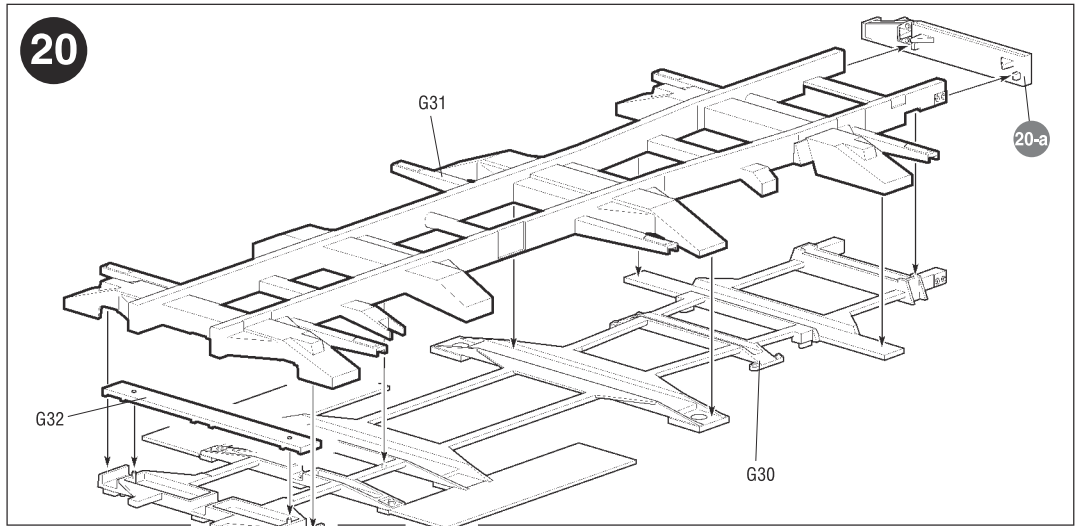
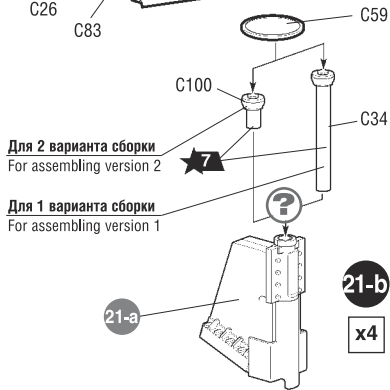
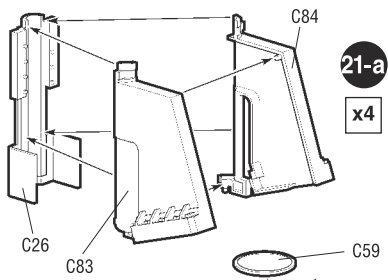
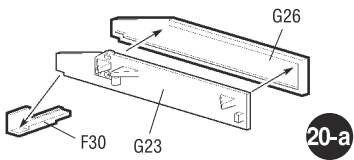

Любые модели и красочный каталог предприятия «ЗВЕЗДА» вы можете приобрести по почте, прислав заявку по адресу:

**141730, Московская область, г. Лобня, ул. Промышленная, д.2, ООО «ЗВЕЗДА»**

[www.zvezda.org.ru](http://www.zvezda.org.ru)

СОХРАНИТЕ ЭТОТ КУПОН ДЛЯ БУДУЩИХ ОБРАЩЕНИЙ

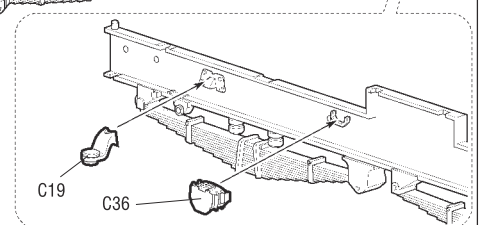
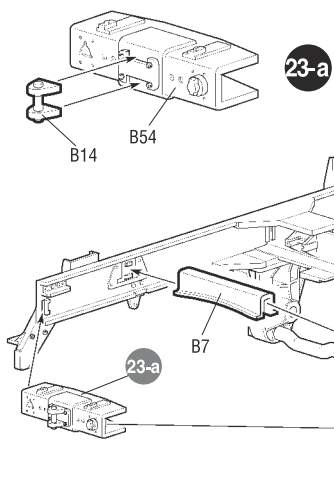
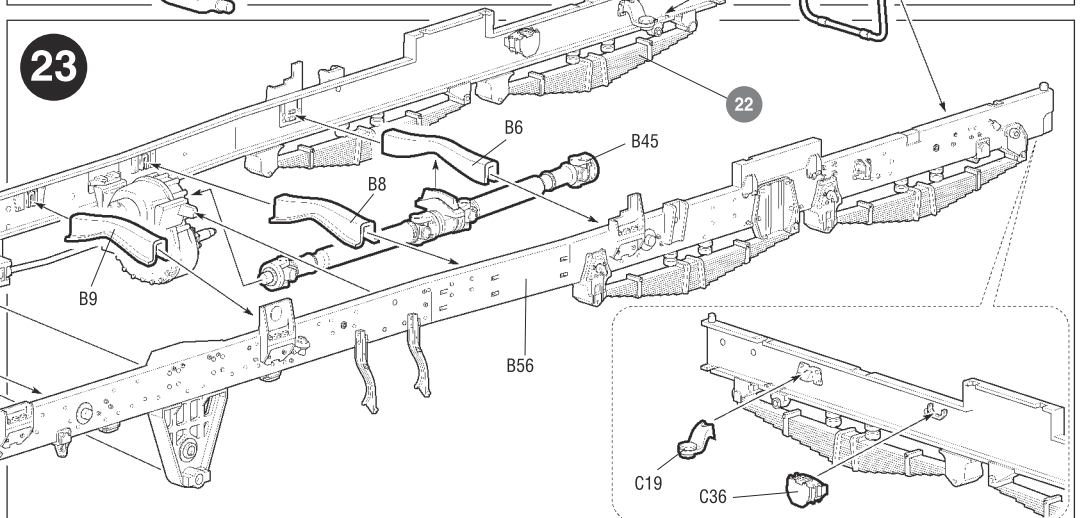
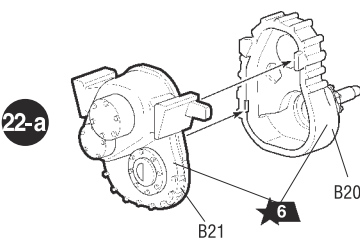
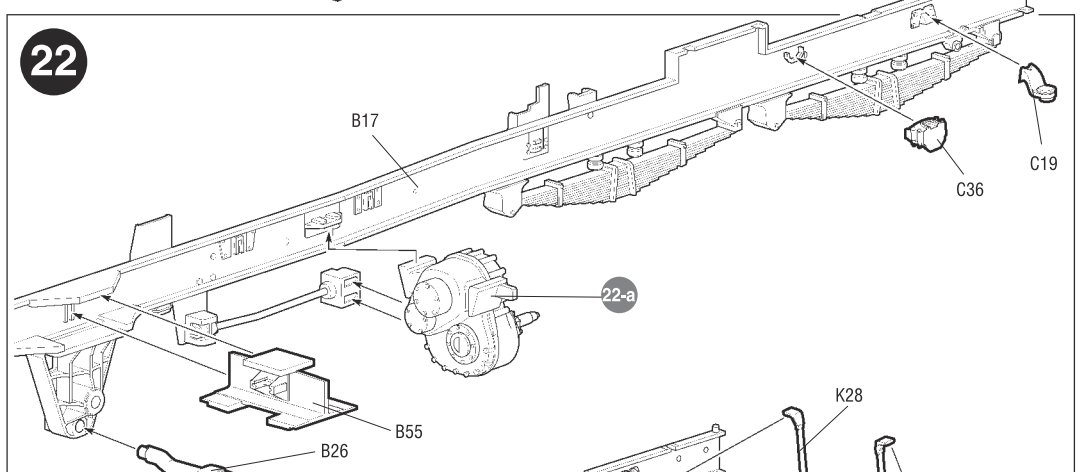

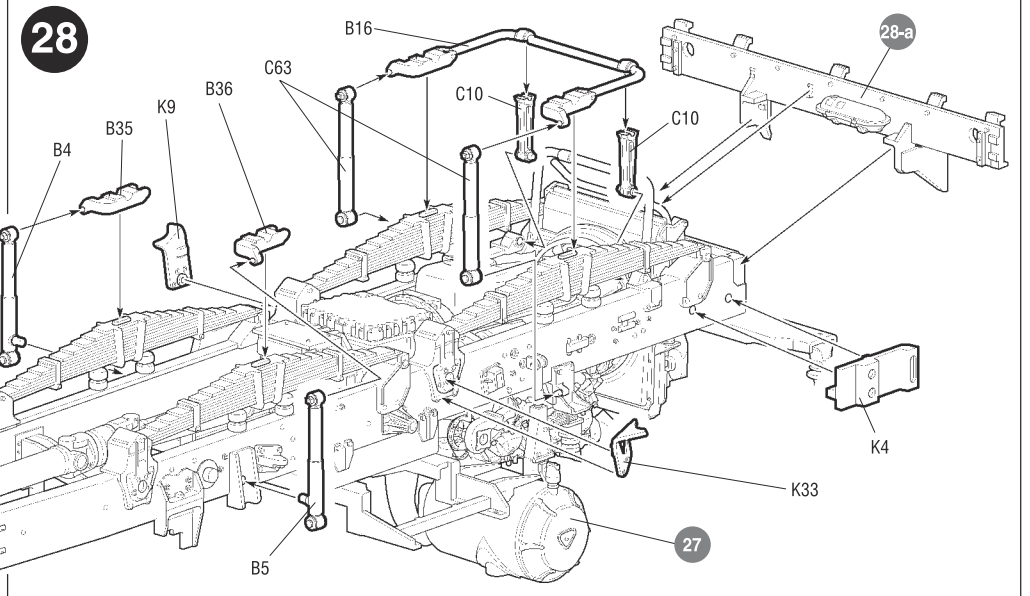
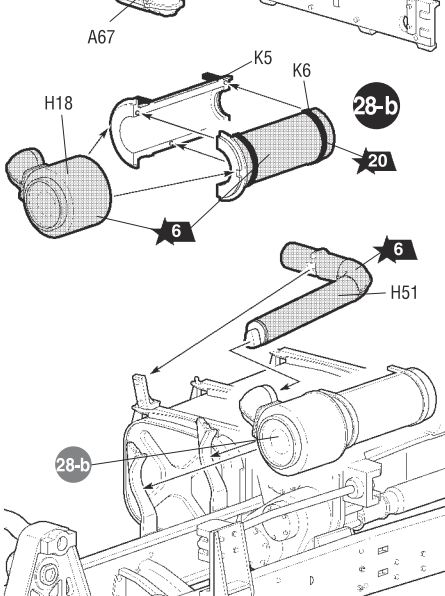
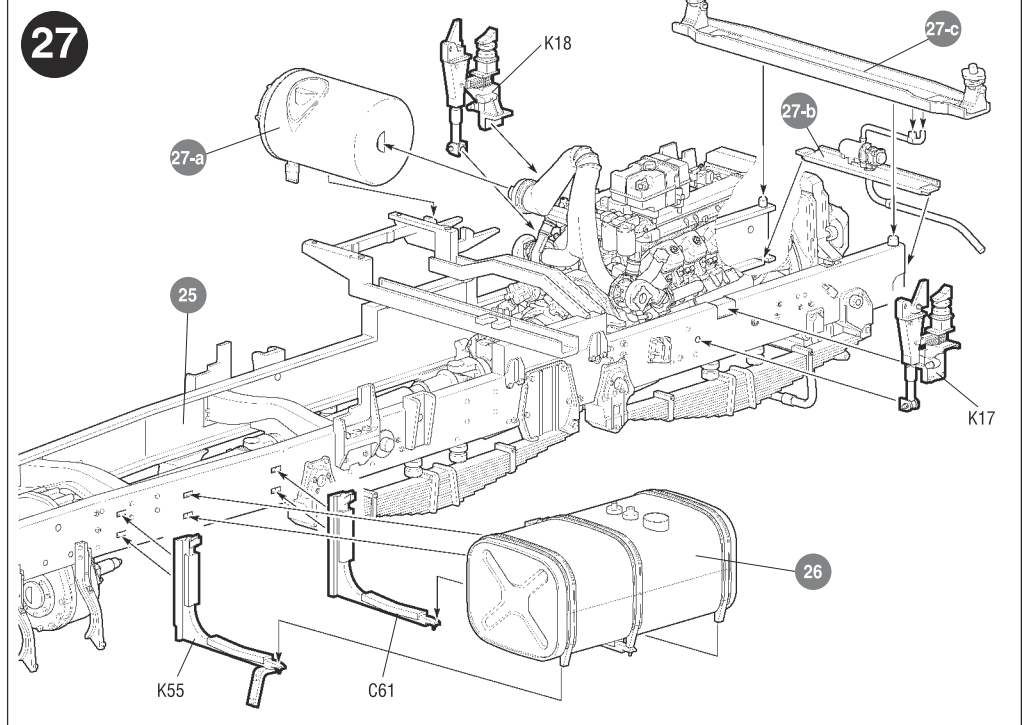
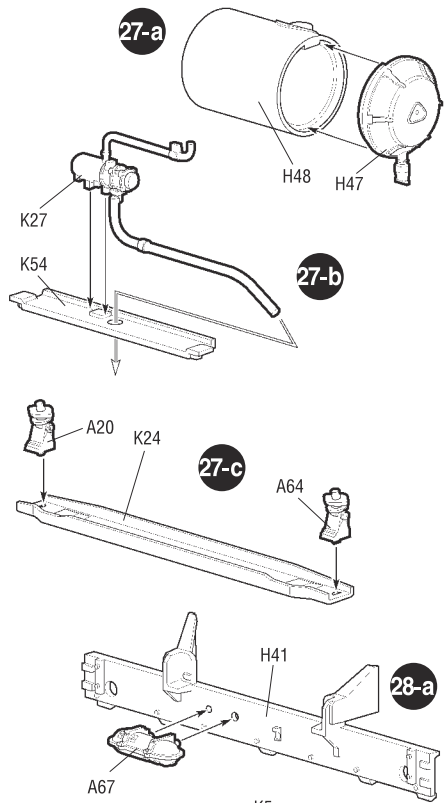
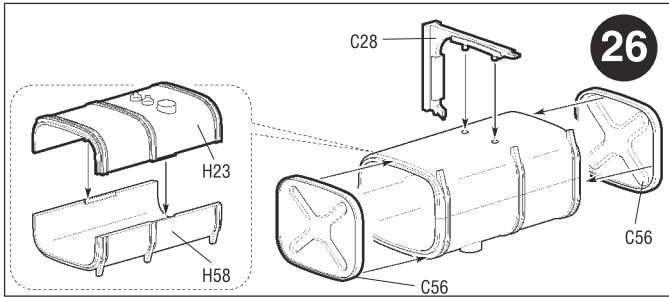
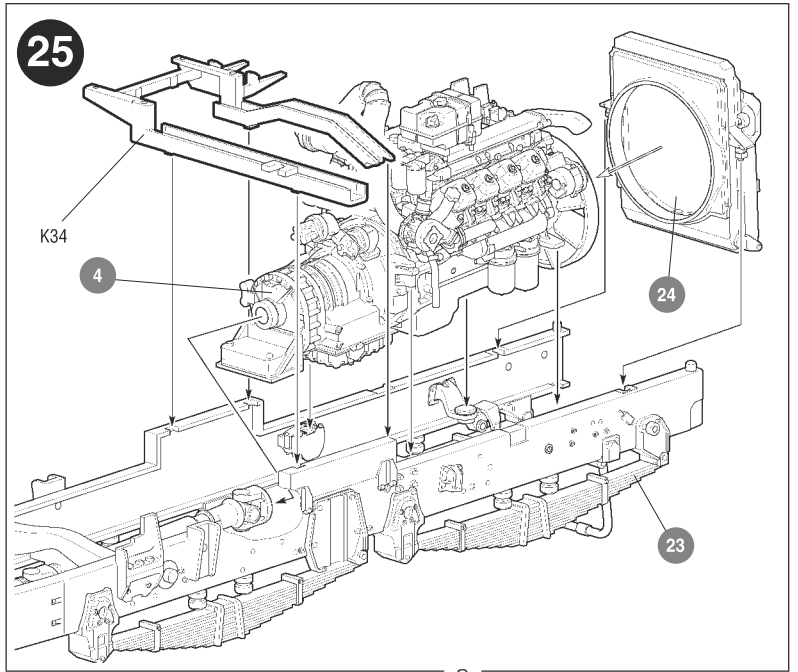
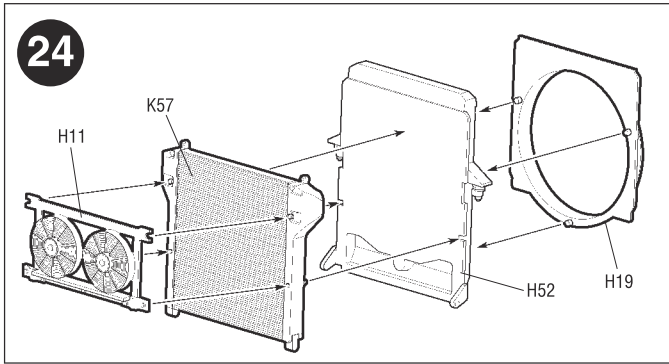



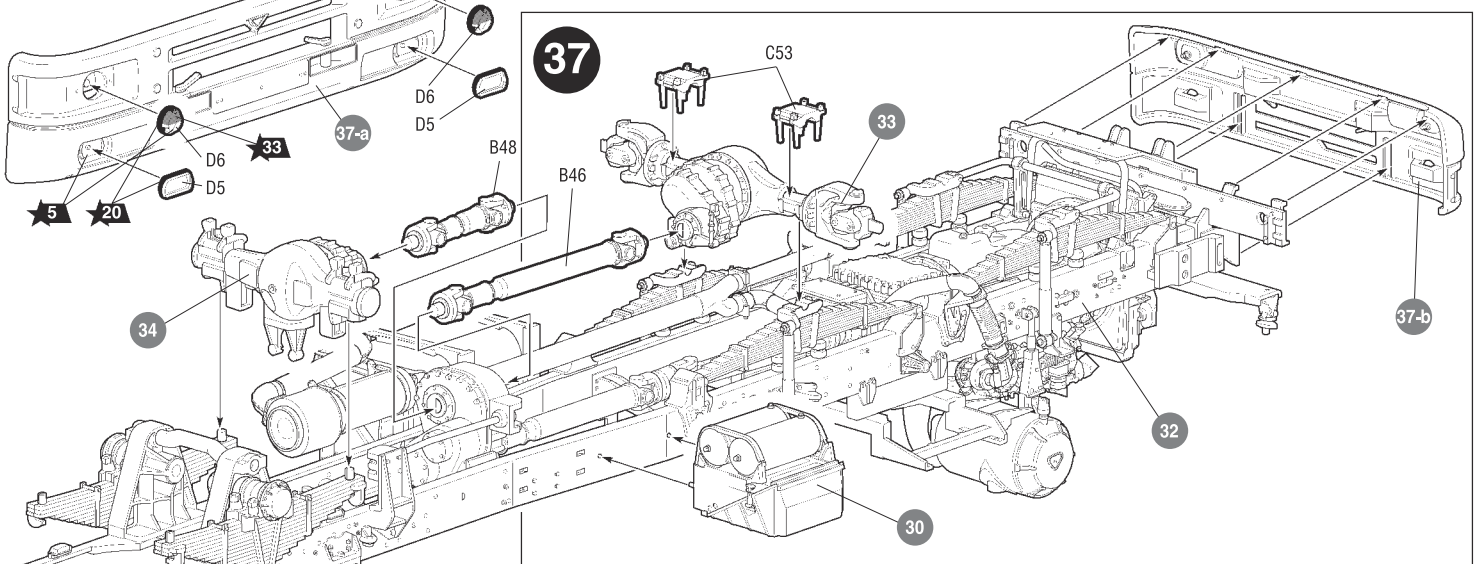
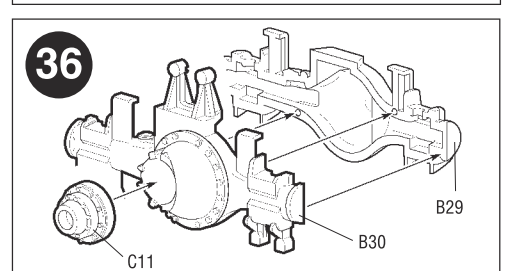
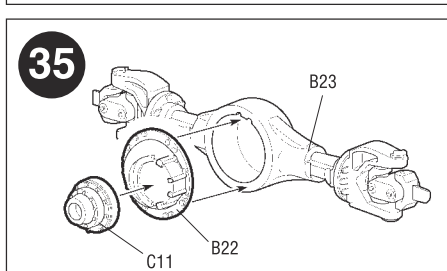
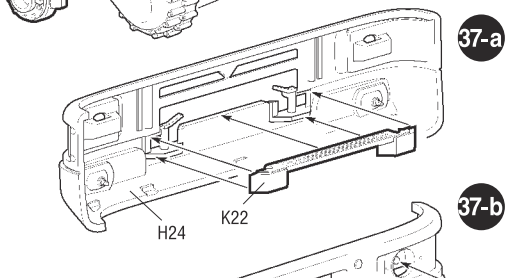
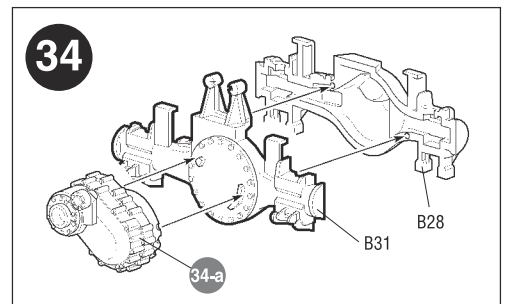
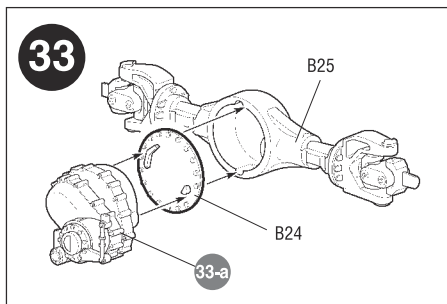
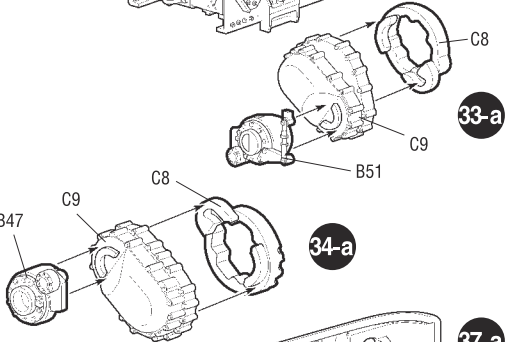
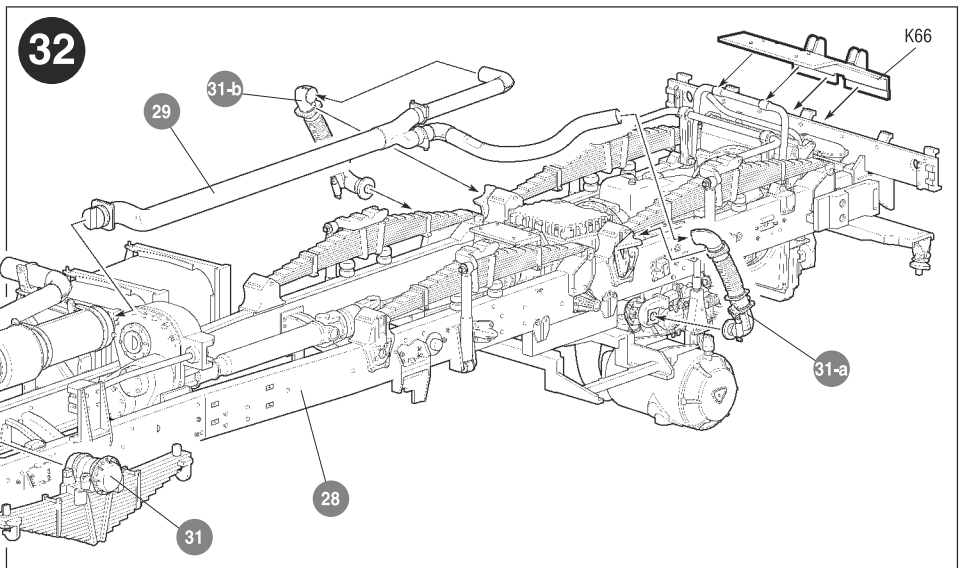
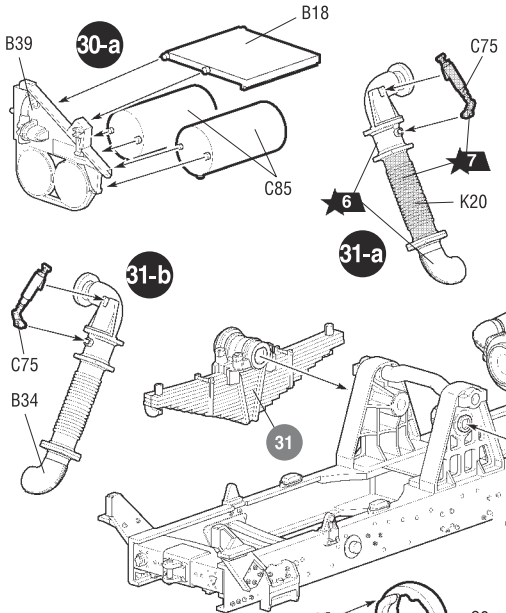
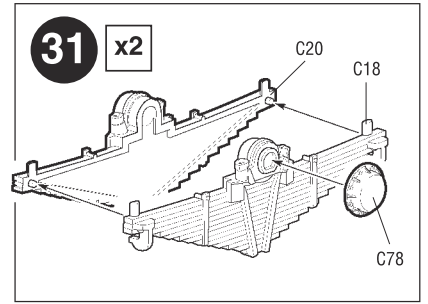
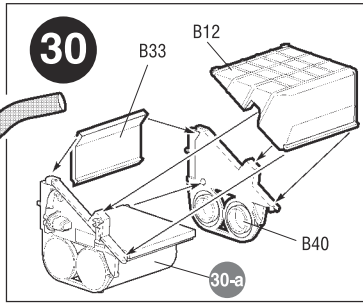
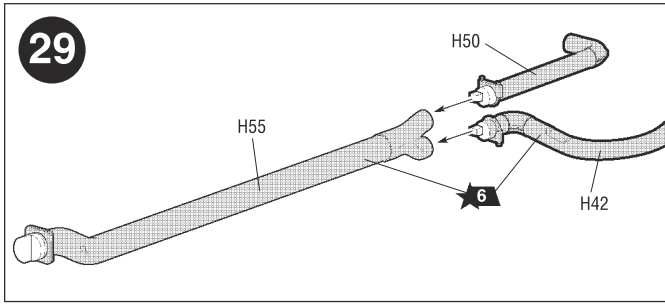

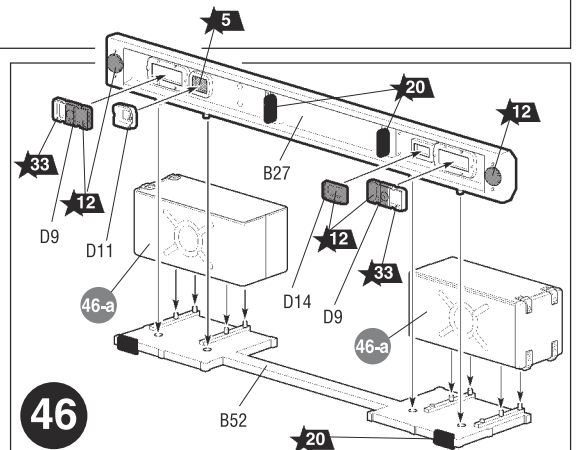
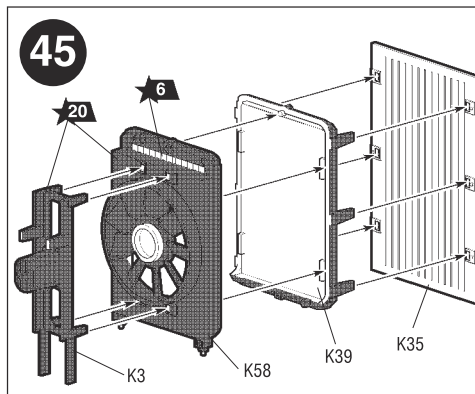
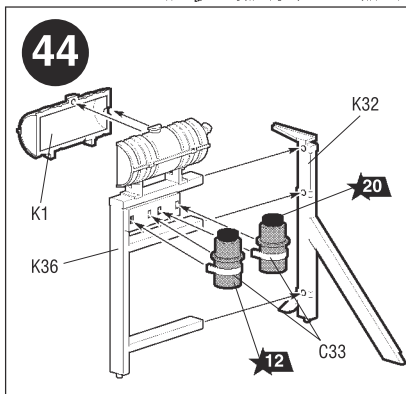
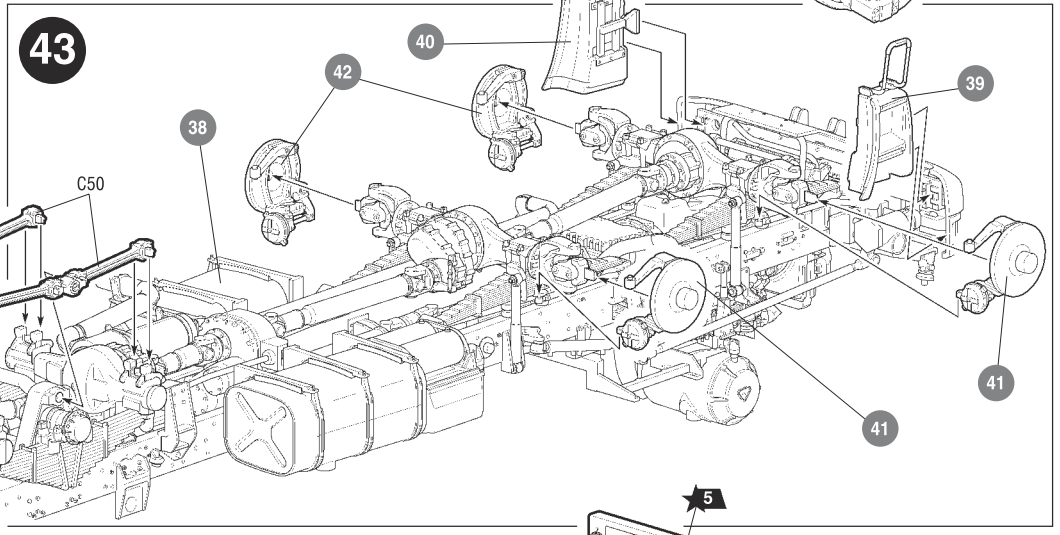
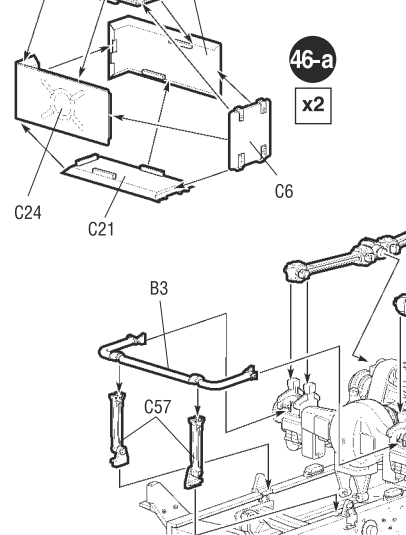
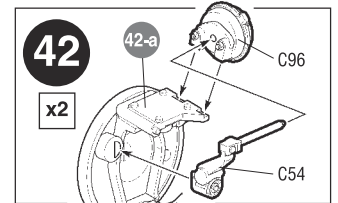
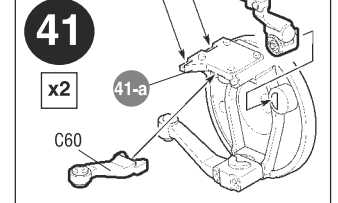
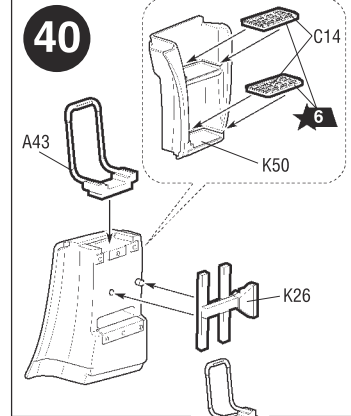
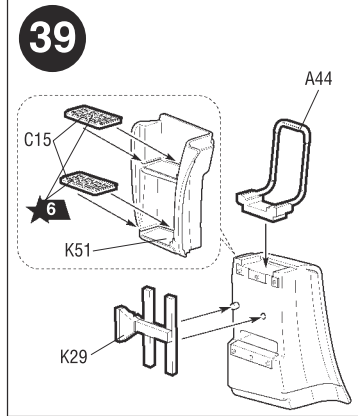
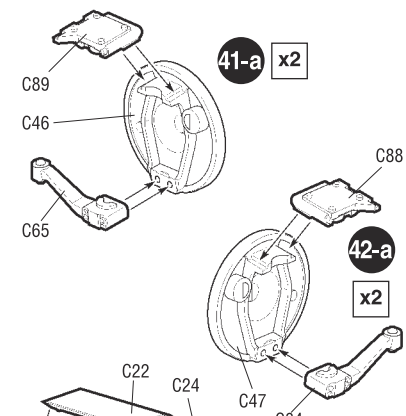
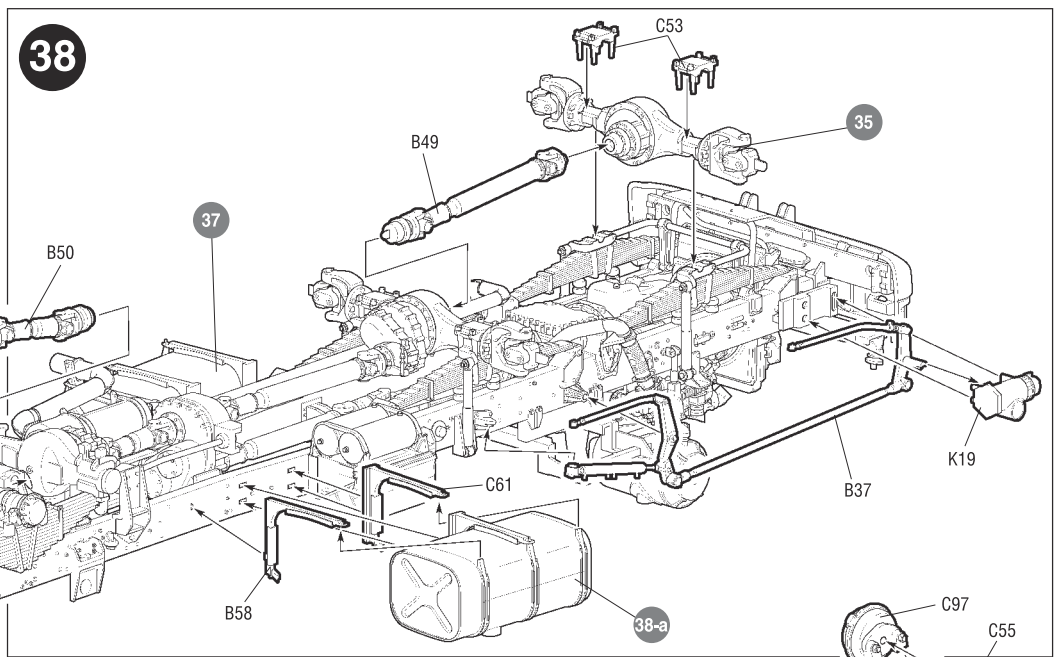
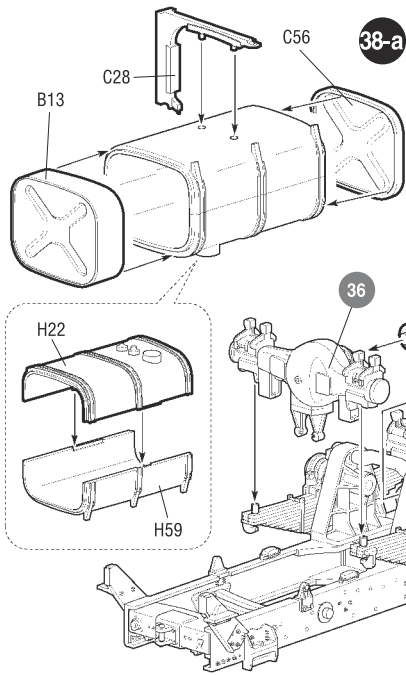

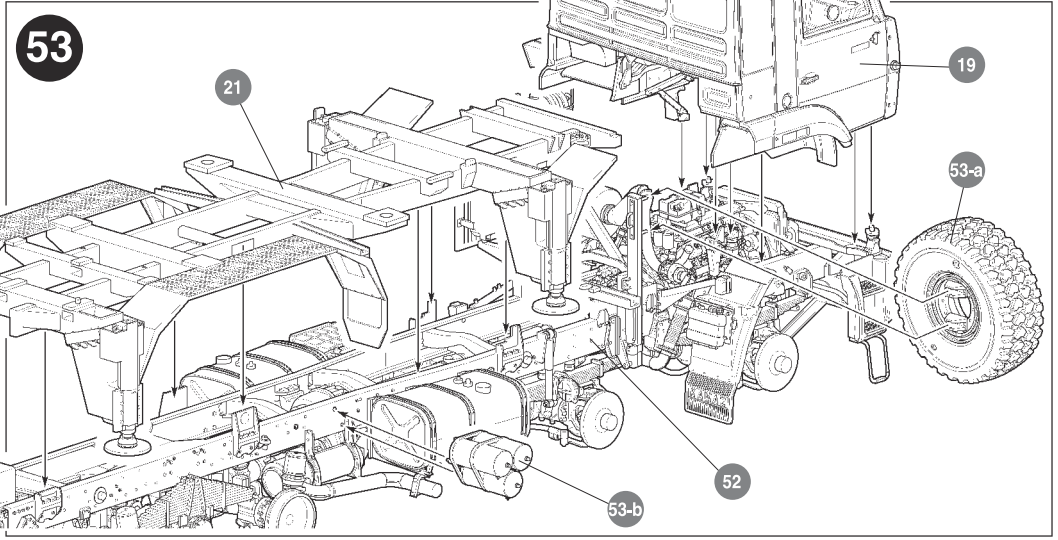
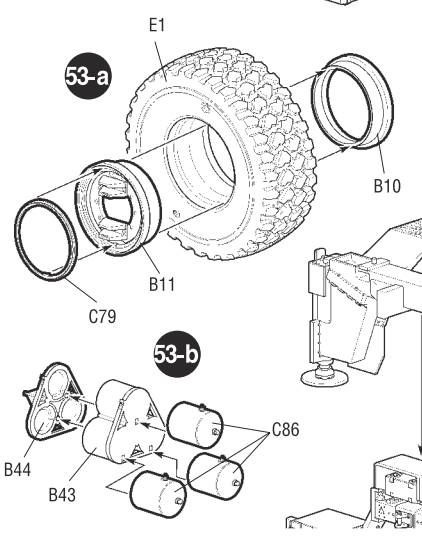
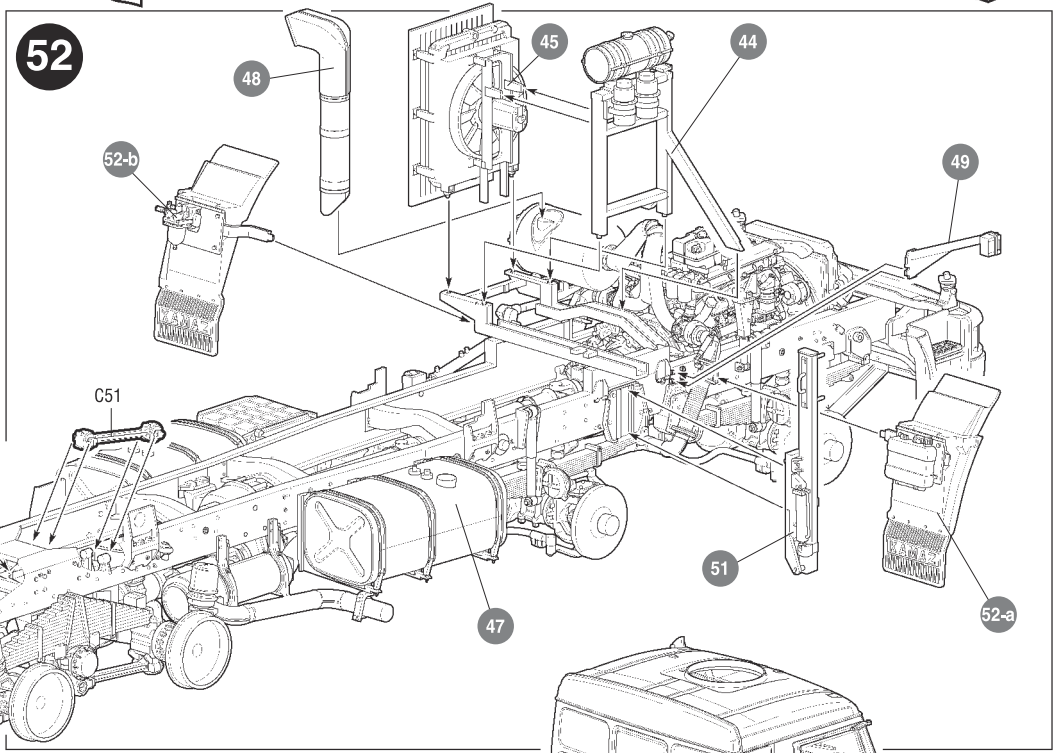
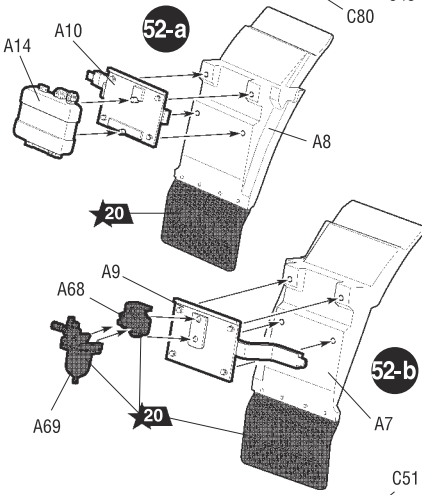
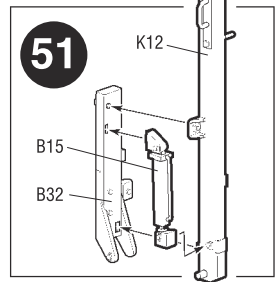
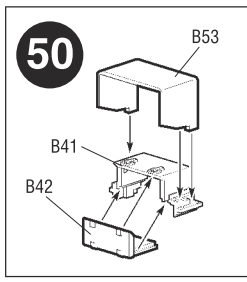
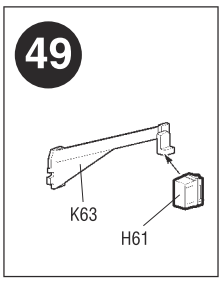
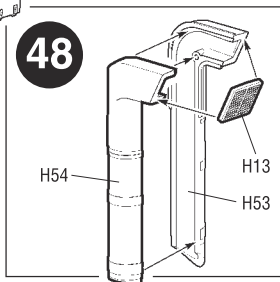
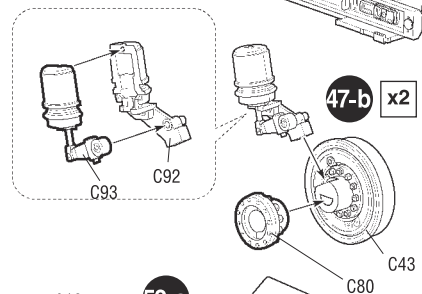
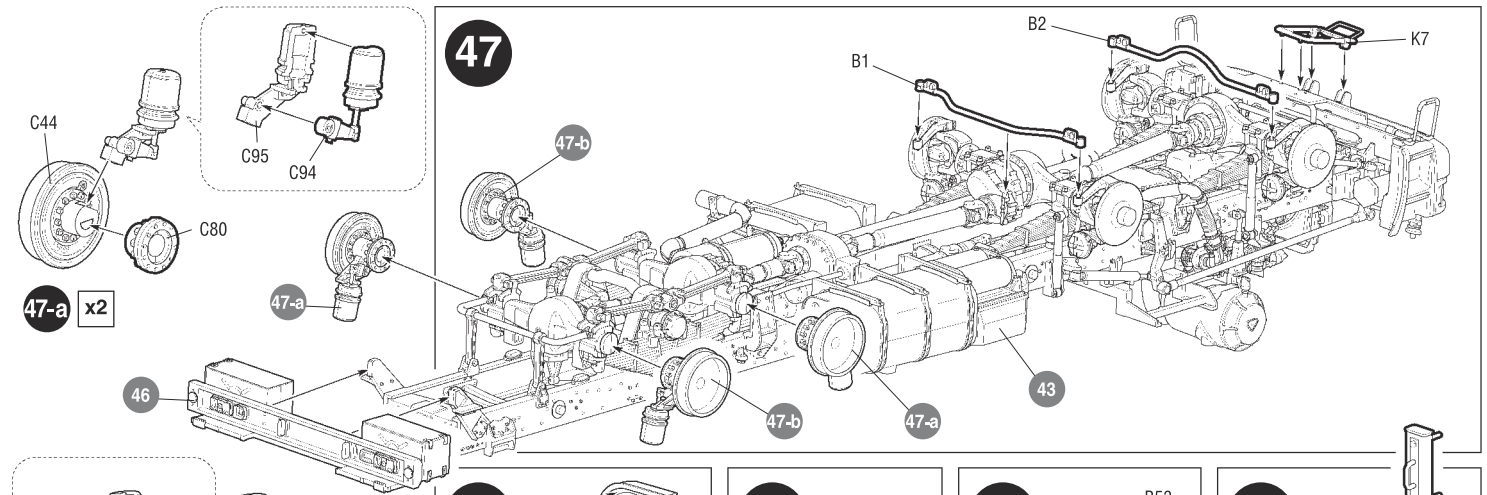

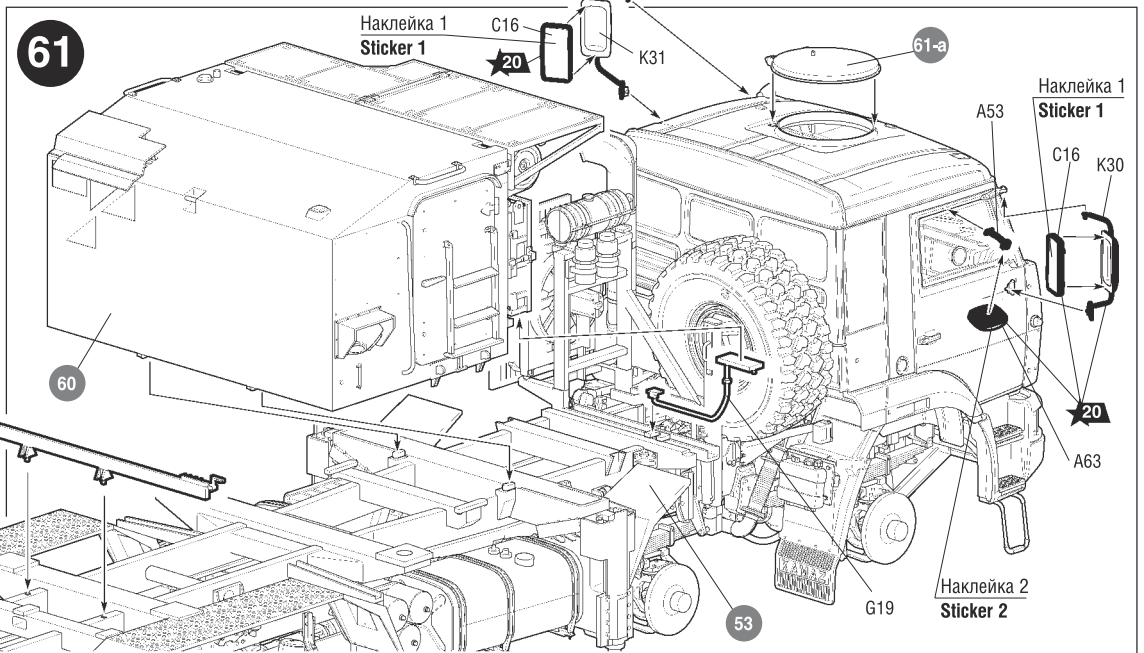
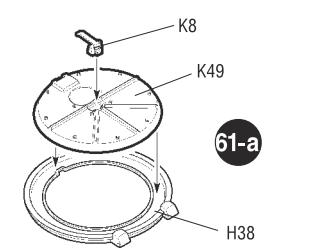
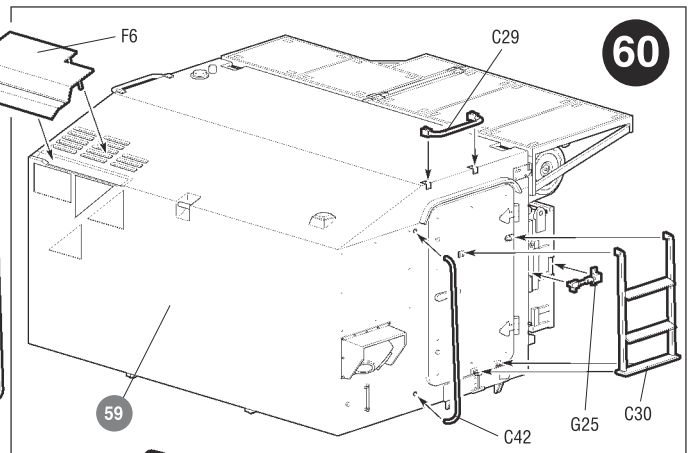
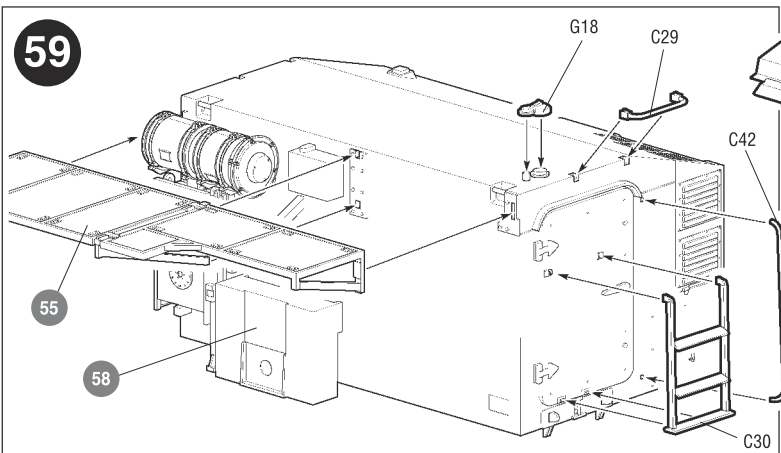
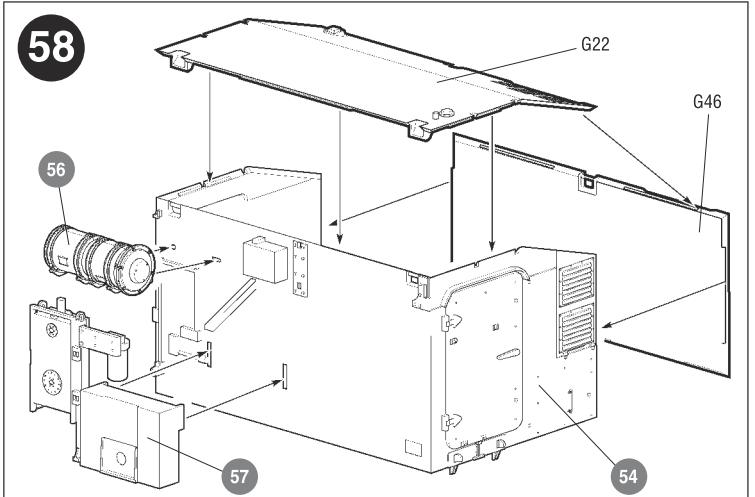
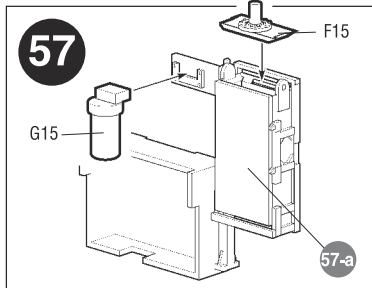
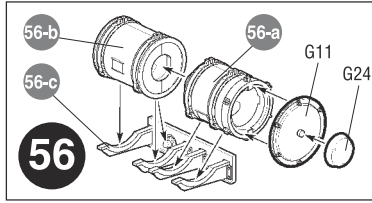
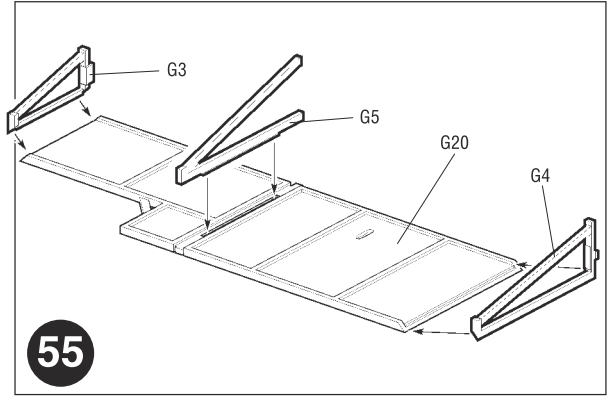
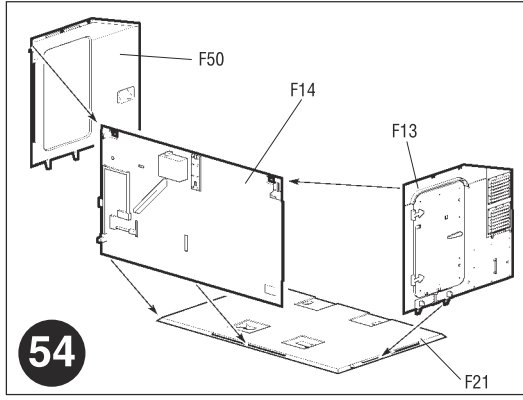
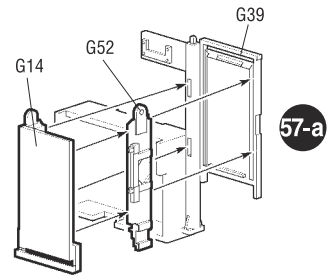
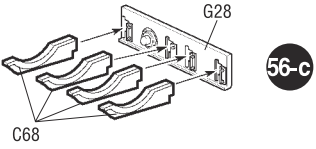
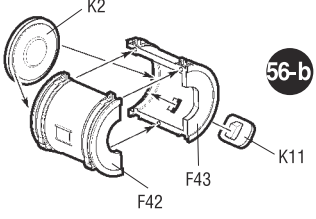
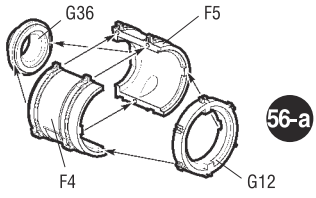

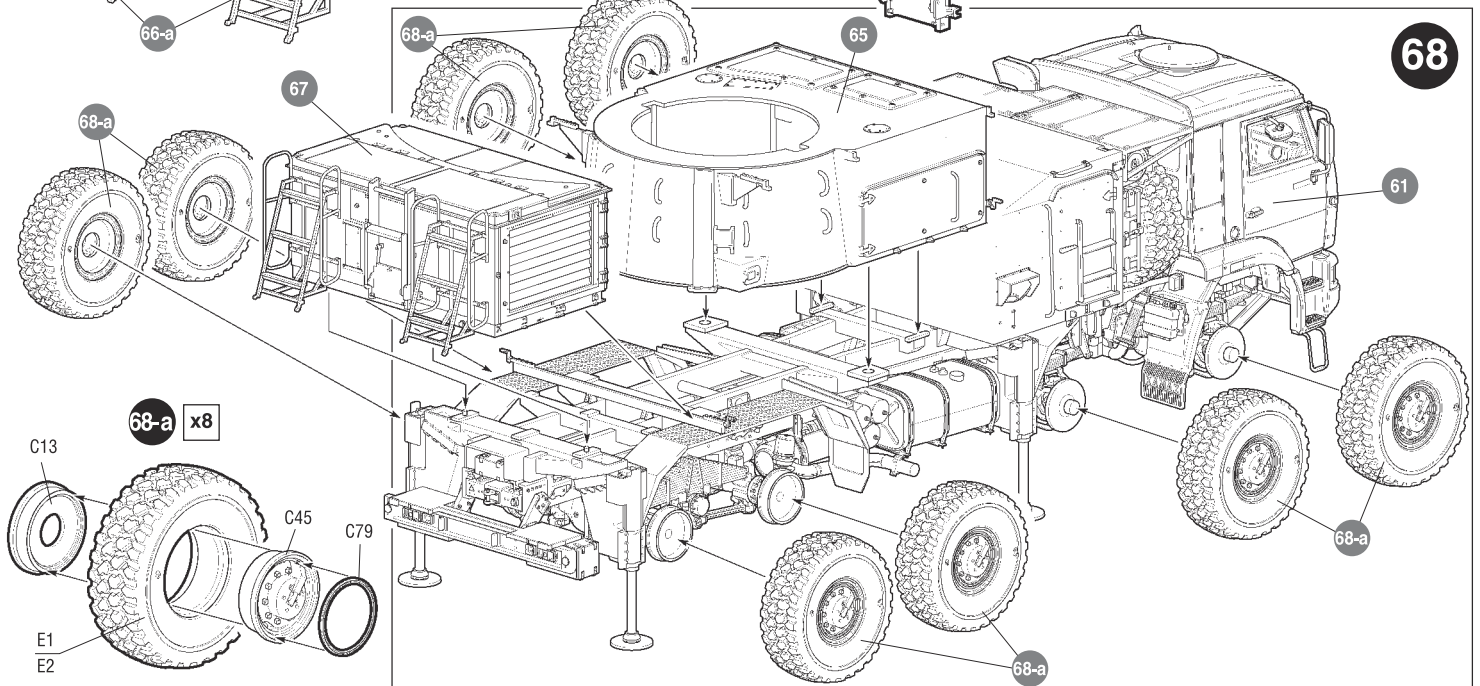
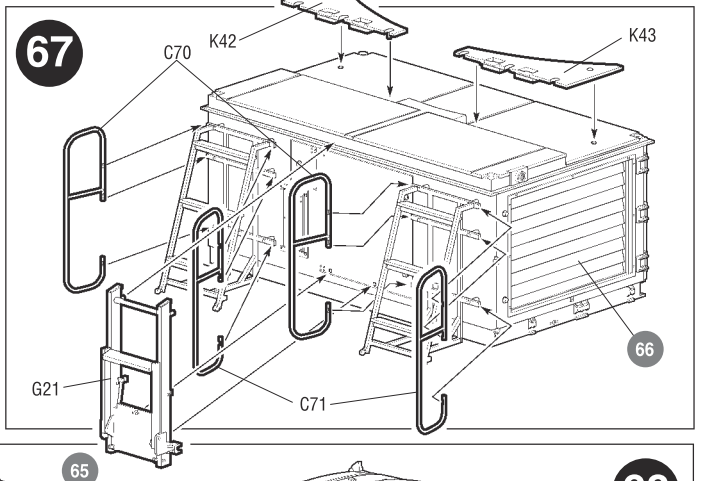
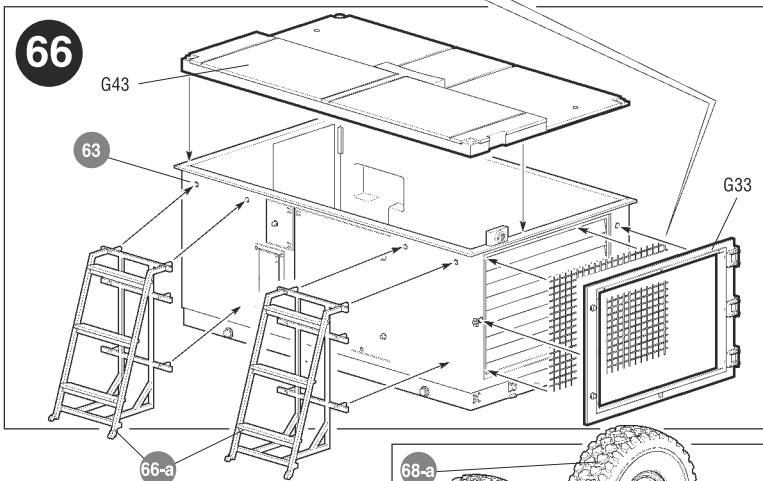
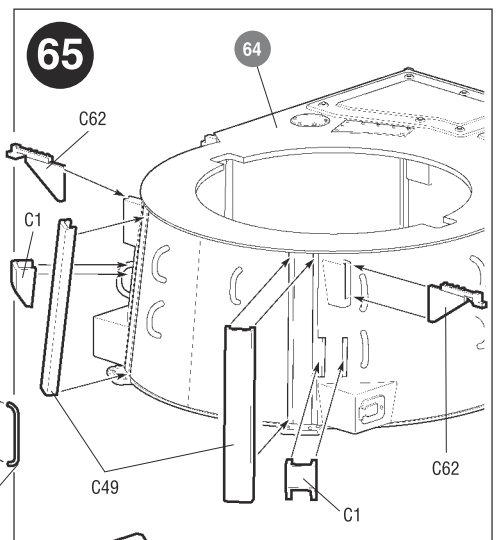
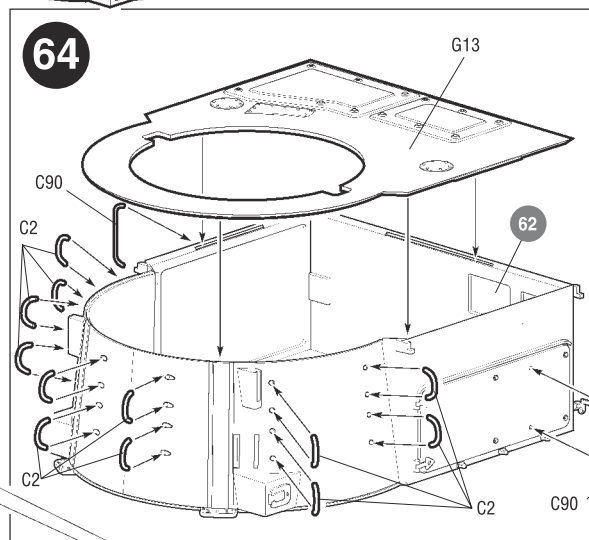
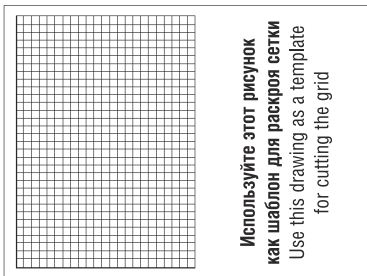
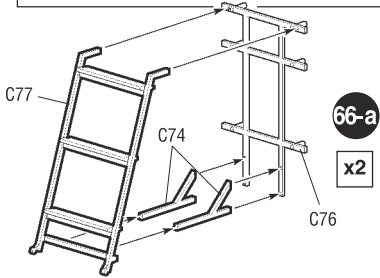
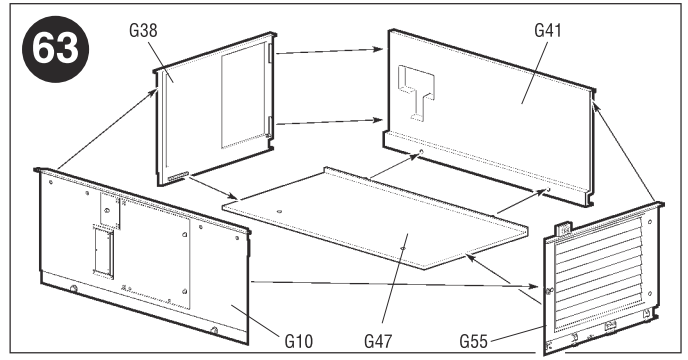
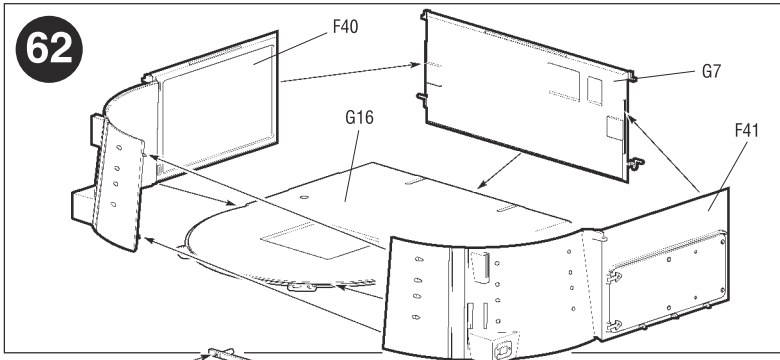

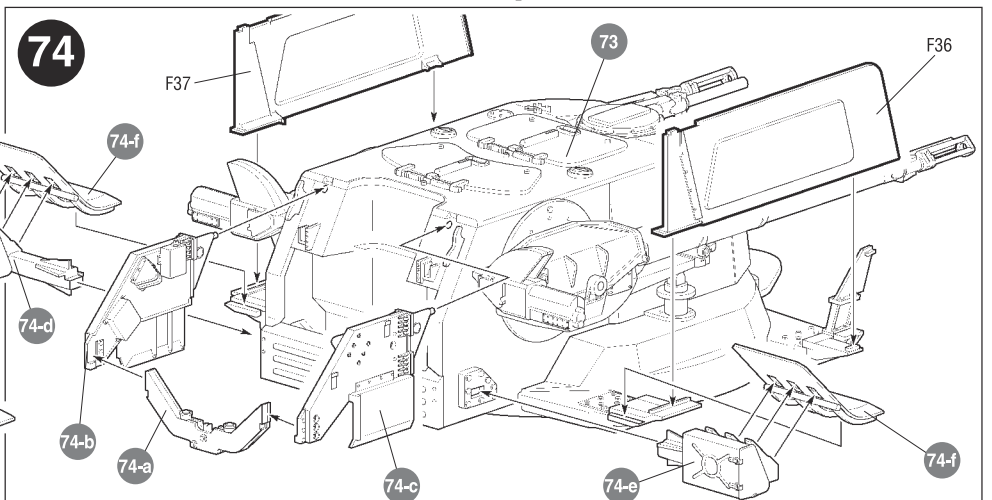
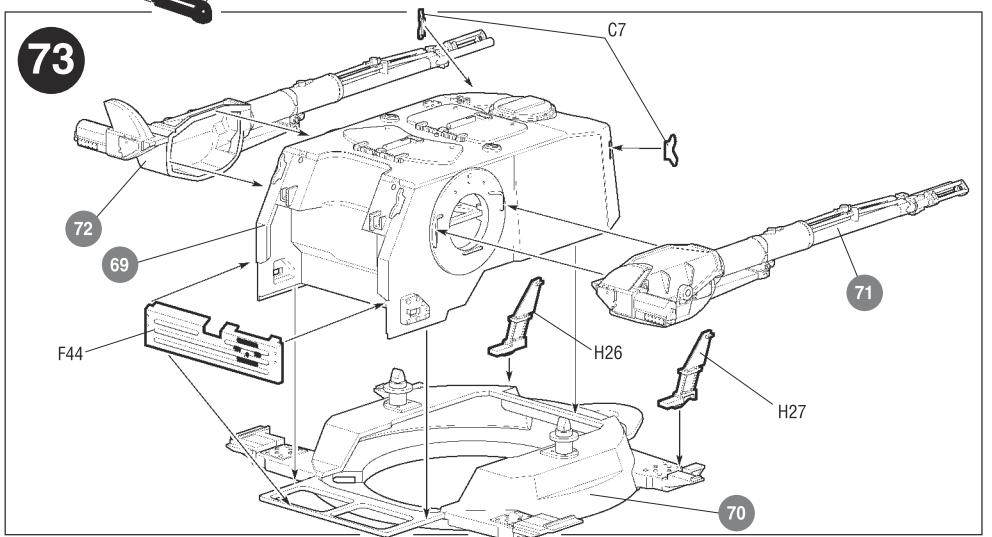
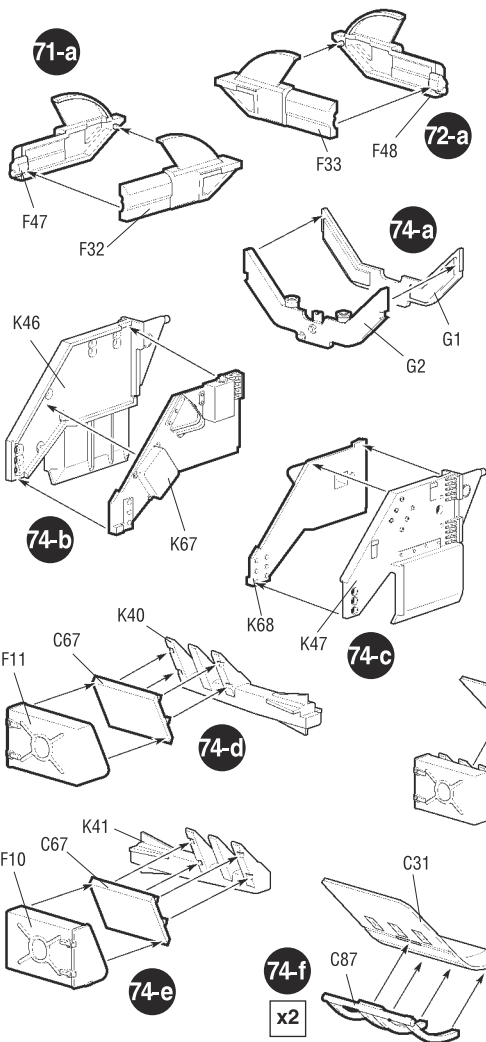
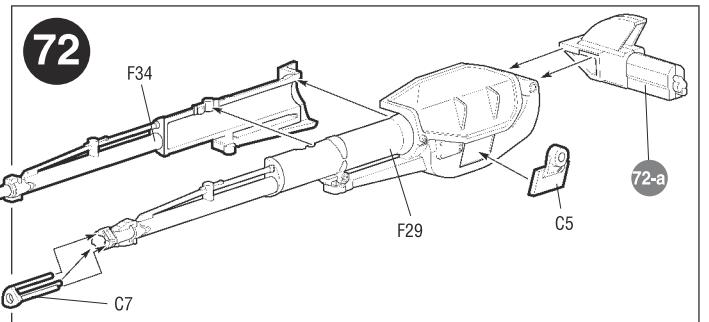
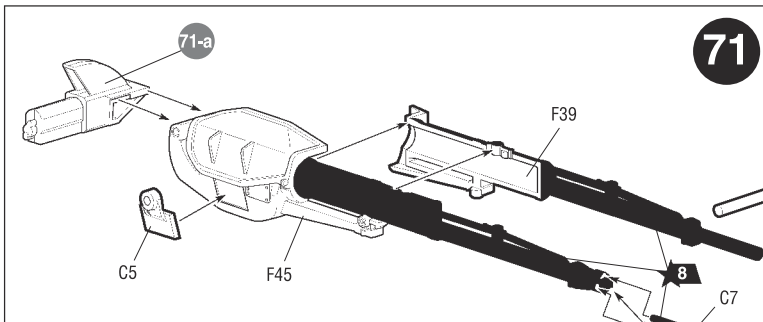
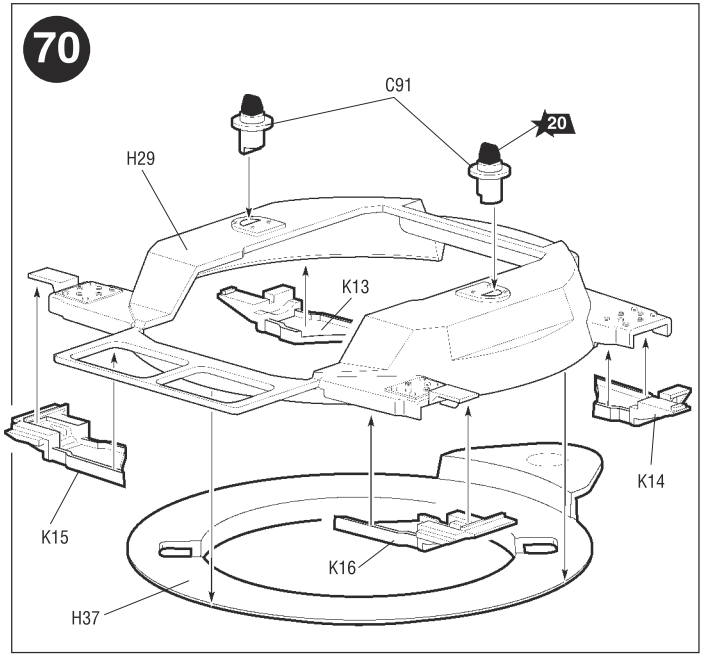
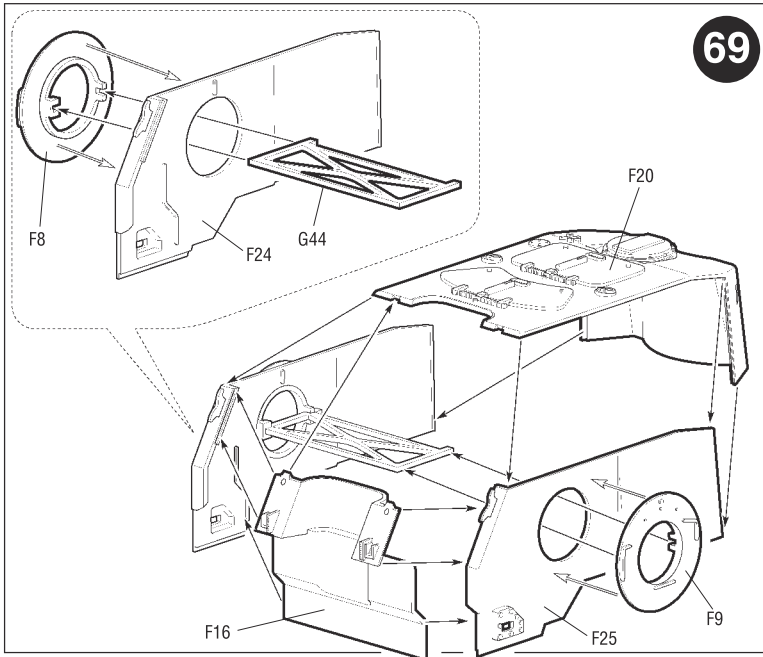

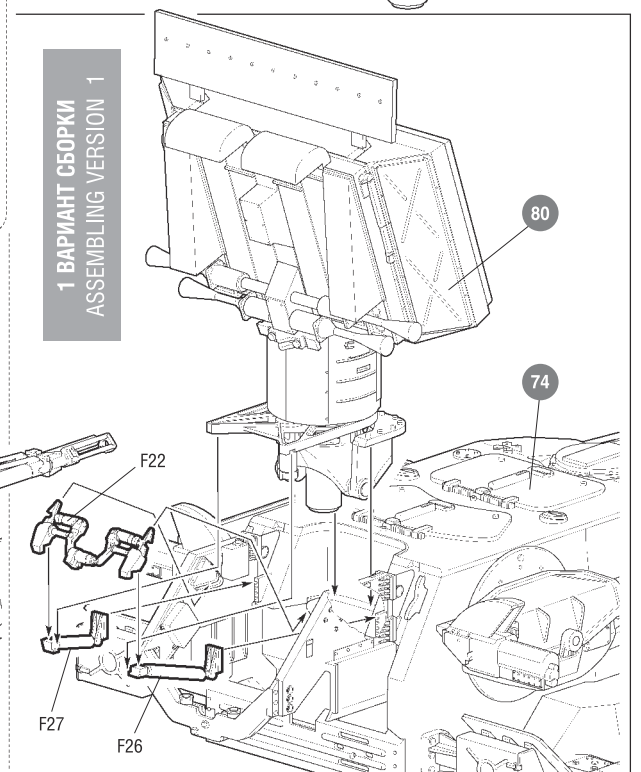
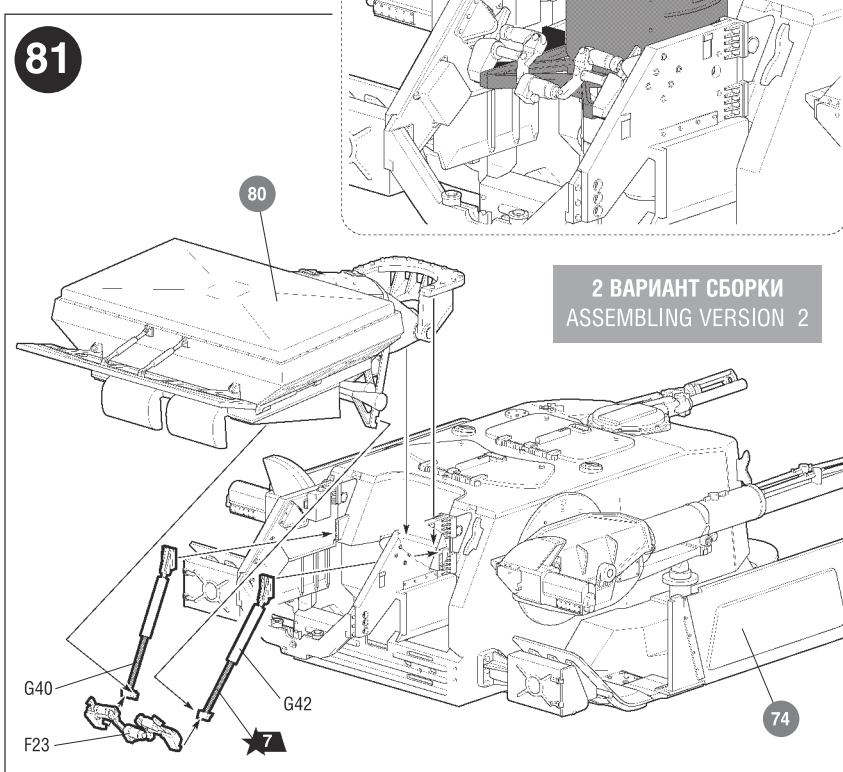
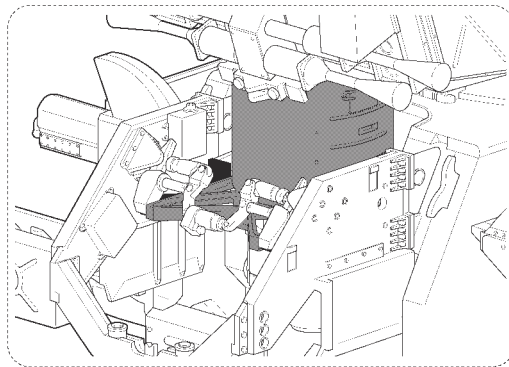
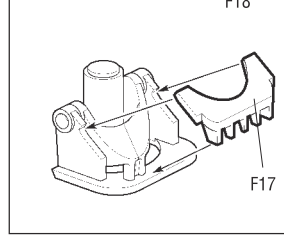
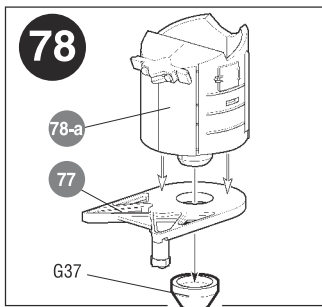
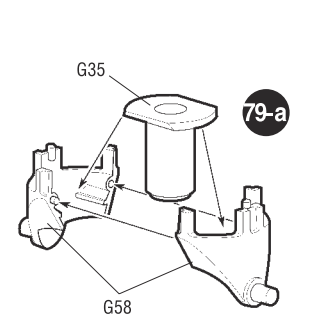
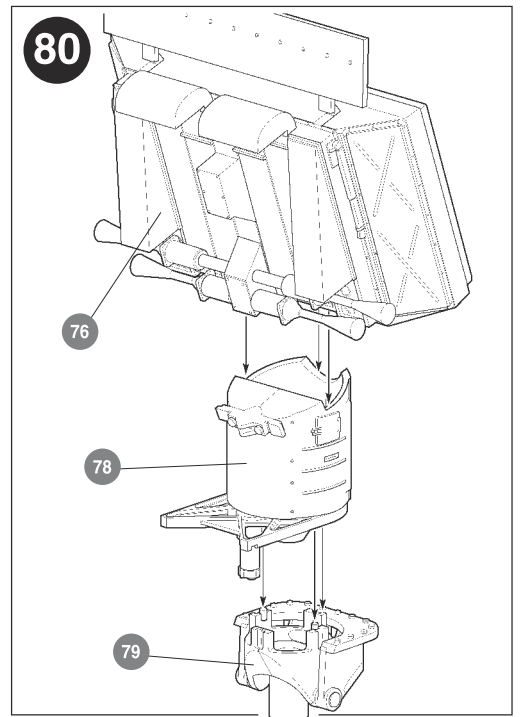
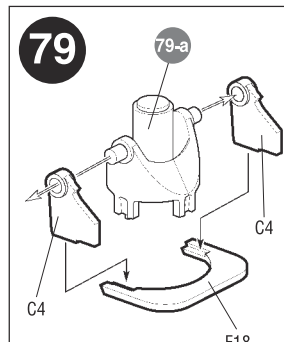
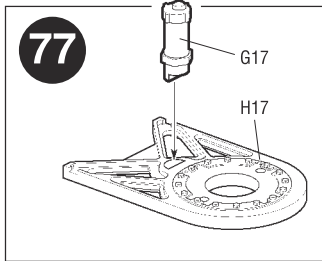
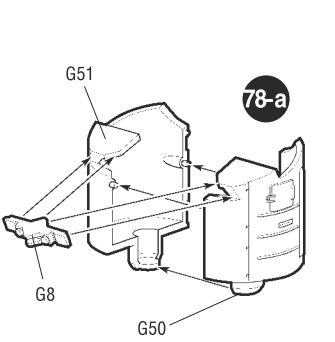
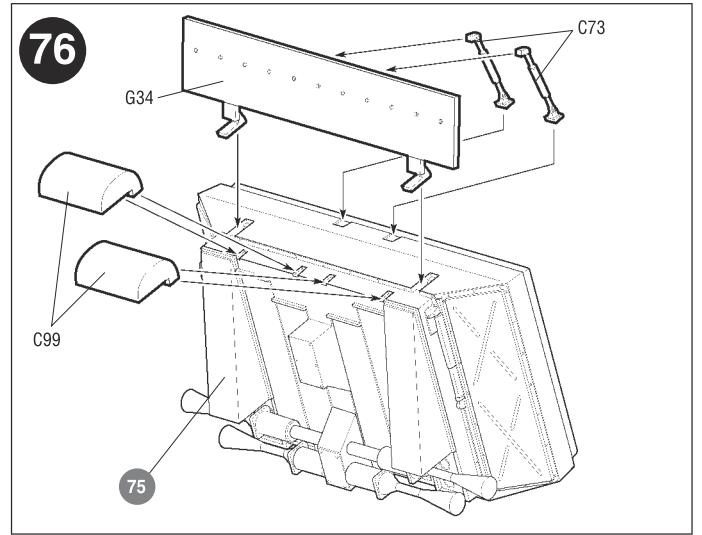
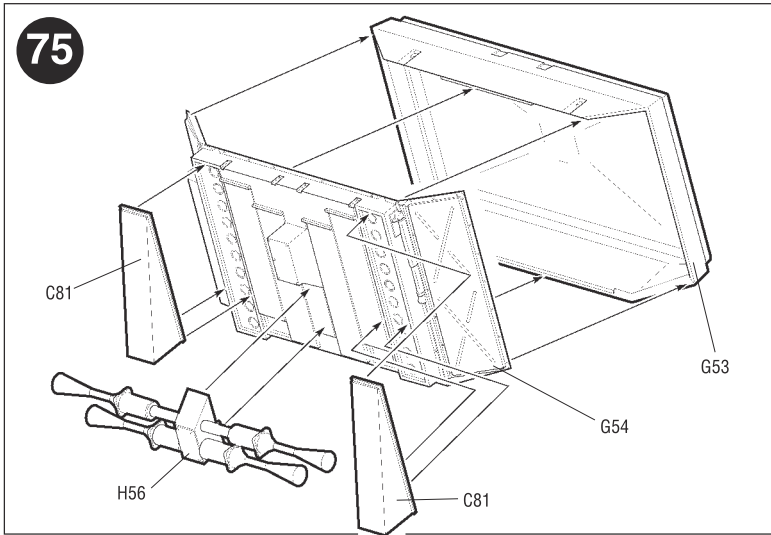

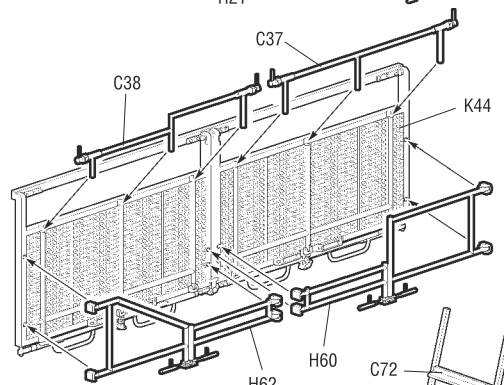
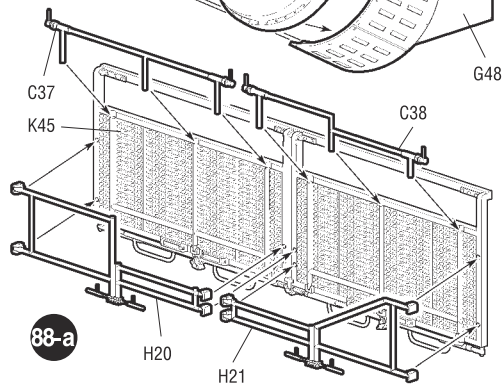
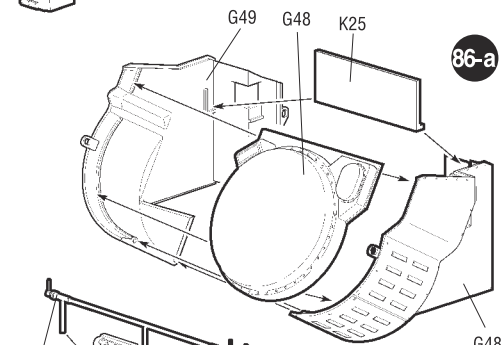
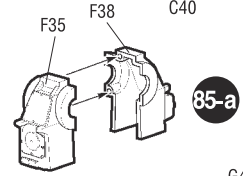
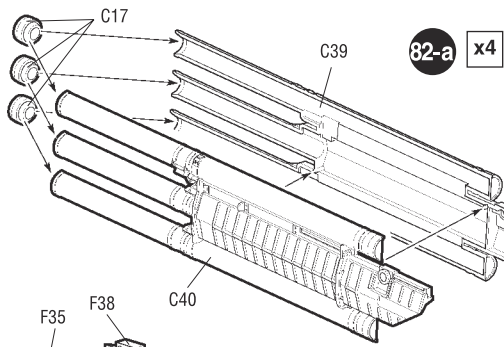

88-c x2

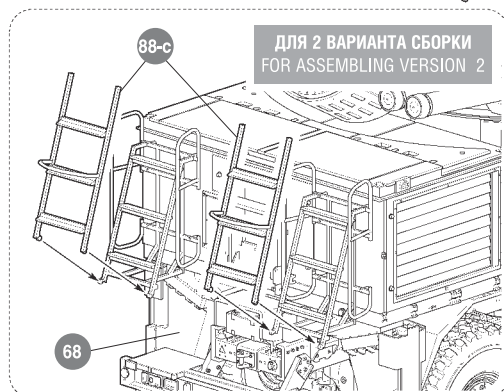

ДЛЯ 2 ВАРИАНТА СБОРКИ  
FOR ASSEMBLING VERSION 2

